

# Carlin®

Combustion Technology

# MODEL 301GAS™

## Gas Burner

## Instruction Manual

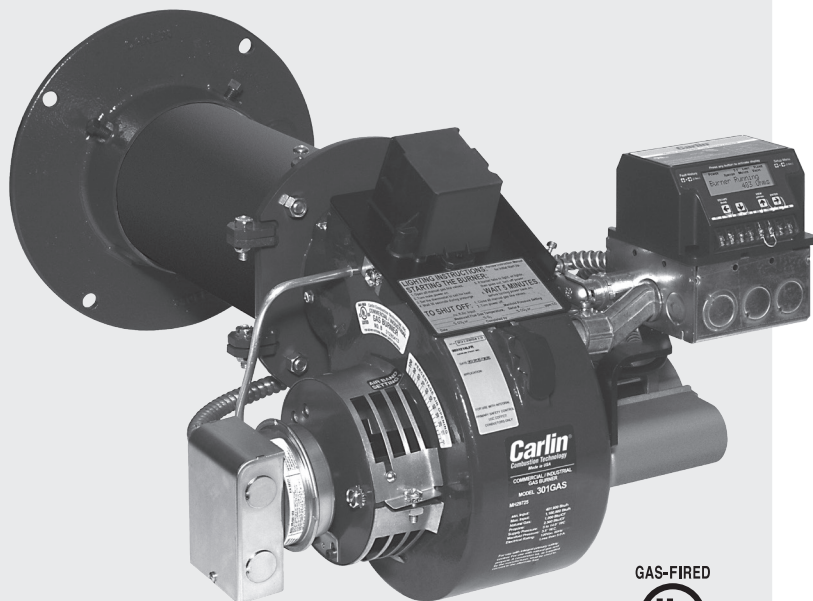

### Ratings

<b>Input:</b>	.....401,000 to 1,100,000 Btuh
<b>Fuels:</b>	..... Natural gas or propane gas
Max. supply pressure	..... 14 inches w.c.
Min. supply pressure	..... 5 inches w.c.
Manifold pressure	..... 3.5 inches w.c.
<b>Electrical:</b>	Power ..... 120V/60 Hz/1-Phase
Motor	..... 1/6 HP, 3450 RPM, 1.8 amps
Total Current	..... Approx. 2.5 amps
<b>Ignition:</b>	..... Carlin Model 41800 solid state ignitor
<b>Control:</b>	..... Carlin Model 60200FR microprocessor control
<b>Agencies:</b>	..... UL Listed

#### WARNING

**Installer/servicer** — Except where specifically stated otherwise, this manual must be used only by a **qualified service technician**. (In the state of Massachusetts, this product must be installed by a licensed Plumber or Gas Fitter.) Failure to comply with this or other requirements in this manual could result in severe personal injury, death or substantial property damage.

#### WARNING

**User** — Refer only to **User's Information** booklet for information regarding operation of this burner. The burner **Instruction Manual** is intended only for your service technician. The burner and heat exchanger must be inspected and started at least annually by your service technician.

### Contents

PLEASE read this first	.....2
Codes and Standards	.....2
301GAS Burner at-a-glance	.....3
Prepare Site • Prepare Burner • Mount Burner	.....4
Install Gas Piping	.....10
Wire Burner	.....11
Check System • Start-up Burner/Appliance	.....13
Perform Checkout Procedures • Fill Out Certificate	.....18
Maintenance and Service Procedures	.....20
Troubleshooting	.....21
Dimensions and Mounting Information	.....23
Replacement Parts	.....24
Installation/Service Certificate	.....26

© Copyright 2021 — Carlin Combustion Technology

**Carlin Combustion Technology**

126 Bailey Road  
Ph 203-680-9401

North Haven, CT 06473  
Fx 203-680-9403

TECH SUPPORT 800-989-2275

carlincombustion.com

## PLEASE read this first . . .

### Special attention flags

Please pay particular attention to the following when you see them throughout this manual.

**DANGER** Notifies you of hazards that **WILL** cause severe personal injury, death or substantial property damage.

**WARNING** Notifies you of hazards that **CAN** cause severe personal injury, death or substantial property damage.

**CAUTION** Notifies you of hazards that **WILL or CAN** cause minor personal injury or property damage.

**NOTICE** Notifies you of special instructions on installation, operation or maintenance that are important, but are not normally related to injury or property damage hazards.

### General information

#### Burner applications

Follow all instructions in this manual and the appliance manual. Where appliance instructions differ from this manual, follow the appliance instructions. Read the label attached to the burner air tube to verify the burner is correct for the appliance being used. See page 8 for procedures.

#### Damage or shortage claims

The consignee of the shipment must file damage or shortage claims immediately against the transportation company.

#### When calling or writing about the burner . . .

Please provide us with the UL serial number and burner model number to assist us in locating information. Enter this information on the Installation Certificate in this manual. The certificate information can be helpful when troubleshooting or obtaining replacement parts.

#### Fill out burner adjustment label

Fill out the burner adjustment label, located on the housing above the rating label after completing installation and burner setup.

**WARNING** Should overheating occur: (1) shut off the manual gas control to the appliance, (2) do not shut off the control switch to the pump or blower.

**WARNING** Follow the guidelines below to avoid potential severe personal injury, death or substantial property damage.

### Installer/service technician . . .

- Read all instructions before proceeding. Perform all procedures, and in the order given to avoid potential of severe personal injury, death or substantial property damage.
- Before leaving the site after start-up or service, review the **User's information** manual with the user. Make the user aware of all potential hazards and perform the training outlined below.

### Train the user . . .

- To properly operate the burner/appliance per this manual and the appliance instructions and the **User's information manual**.
- To keep this manual at or near the burner/appliance for ready access by the user and service technician.
- To contact the service technician, gas supplier or fire department should the user smell gas.
- To keep the appliance space **free of flammable liquids or vapors and other combustible materials**.
- Do not use laundry products, paints, varnishes or other chemicals in the room occupied by the burner/appliance.
- To contact the service technician at least annually for start-up and burner/appliance service.

### When servicing the burner . . .

- **Disconnect electrical supply** to burner before attempting to service to avoid electrical shock or possible injury from moving parts.
- Burner and appliance components can be extremely hot. **Allow all parts to cool** before attempting to handle or service to avoid potential of severe burns.

## Codes and Standards

**NOTICE** The installer/servicer is solely responsible for compliance with all applicable codes and standards.

### Burner listings

Carlin 301GAS burners are tested and approved under standards UL795 and CGA 3.4-latest edition.

### Codes

Burner/appliance installations must comply with all applicable local codes and, where applicable, with the National Fuel Gas Code, ANSI Z223.1/NFPA 54-latest edition, and the National Electrical code, ANSI/NFPA 70-latest edition for U. S. installations or B149.1/B149.2 Installation Code, and CSA C22.1 Canadian Electrical Code Part 1 for Canadian installations.

### For Massachusetts Applications

1. For 301GAS burner applications in the Commonwealth of Massachusetts, the burner input may not exceed 999,999 Btuh.
2. Model 301GAS burners for use in the Commonwealth of Massachusetts must be equipped with Carlin 60200FRN non-recycling primary controls. these controls will lockout on flame failure.

Where appliance instructions differ from this manual, follow the appliance instructions.

## 301GAS Burner at-a-glance

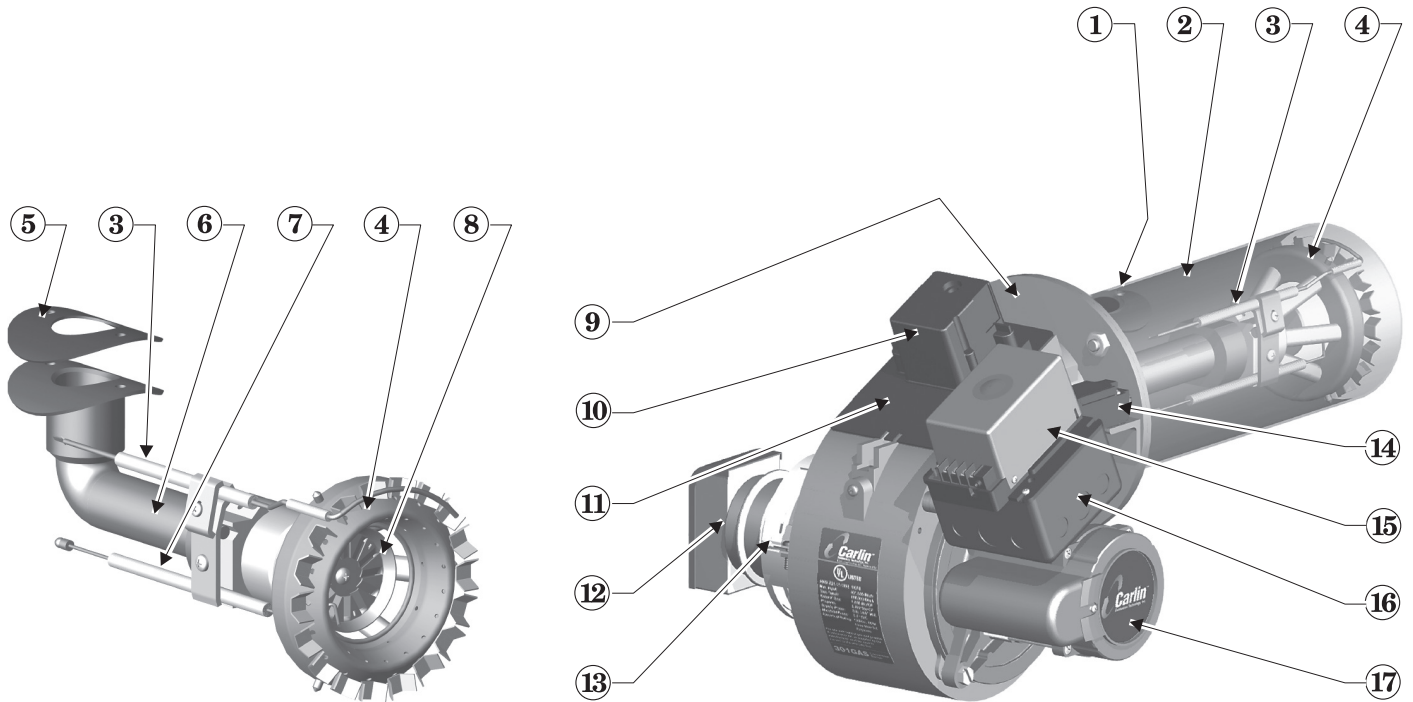

- |   |   |
|---|---|
| <ul style="list-style-type: none"> <li>1 Burner gas connection, 1" NPT</li> <li>2 Air tube (flange omitted for clarity), with powder coat paint finish</li> <li>3 Flame rod/insulator assembly</li> <li>4 Combustion head</li> <li>5 Gas saddle connection gasket</li> <li>6 Gas manifold</li> <li>7 Ignition electrode/insulator assembly</li> <li>8 Static disk assembly (low input range shown)</li> <li>9 Hinged burner flange door – for access and removal of combustion head/gas manifold assembly</li> <li>10 Ignitor (Carlin Model 41800 solid state electronic ignitor — 9,000 volts, continuous duty rated)</li> </ul> | <ul style="list-style-type: none"> <li>11 Hinged cover plate (for access to blower wheel &amp; electrodes)</li> <li>12 Airflow proving switch — Prevents burner from firing if air is not moving</li> <li>13 Air band — Only a single adjustment required for setting combustion air; see page 7 for starting setting based on input</li> <li>14 Door interlock switch — prevents burner operation if flanged door is open</li> <li>15 Primary control — Carlin Model 60200FR microprocessor-based interrupted ignition flame supervisory control (flame rectification)</li> <li>16 Burner junction box (installer electrical entrance)</li> <li>17 Motor (with permanently-lubricated bearings and thermal overload protection)</li> </ul> |
|---|---|

# 1. Prepare Site • Prepare Burner • Mount Burner

## Vent system

### Inspect, repair and/or replace vent system

**WARNING** Do not install this burner unless you have verified the entire vent system and the appliance are in good condition and comply with all applicable codes. And . . .

The vent and chimney must be sized and constructed in accordance with all applicable codes. If intended for use with an oil burner as well, the vent system must comply with relevant codes for both gas and oil firing.

The vent system must not be pressurized unless the vent piping and vent system are designed accordingly. The vent must provide draft at all times (negative pressure in vent).

Do not install or use an existing manual damper in the vent connector or vent.

Do not connect the appliance vent connector to a chimney or vent serving a fireplace, incinerator or solid-fuel-burning apparatus.

**In a cold climate, do not vent into a masonry chimney that has one or more sides exposed to the outside. Install a listed stainless steel liner to vent the flue products.**

A defective vent system could result in severe personal injury, death or substantial property damage.

### Vent/chimney sizing

- Follow all local codes when sizing the vent and chimney.
- Refer to the appliance manufacturer's manual, when available, for venting recommendations.

### Prepare vent/chimney

- Secure all metal vent joints with screws, following the vent manufacturer's instructions. Seal all joints in the vent system and chimney. Repair masonry chimney lining and repair all mortar joints as needed.
- Per ANSI Z21-8, install a double-acting barometric draft regulator in the vent piping. (The damper must be located in the same space as the appliance.) Install a manual reset spill switch on the draft regulator outlet per instructions. Wire the switch into the appliance limit circuit to shut off the appliance/burner if sustained downdraft should occur. Refer to the appliance manufacturer's instruction manual for recommendations regarding the need for a barometric draft regulator.
- Provide support for the vent piping. Do not rest the weight of any of the vent piping on the appliance flue outlet.

Figure 1 Vent and vent connector installations, typical

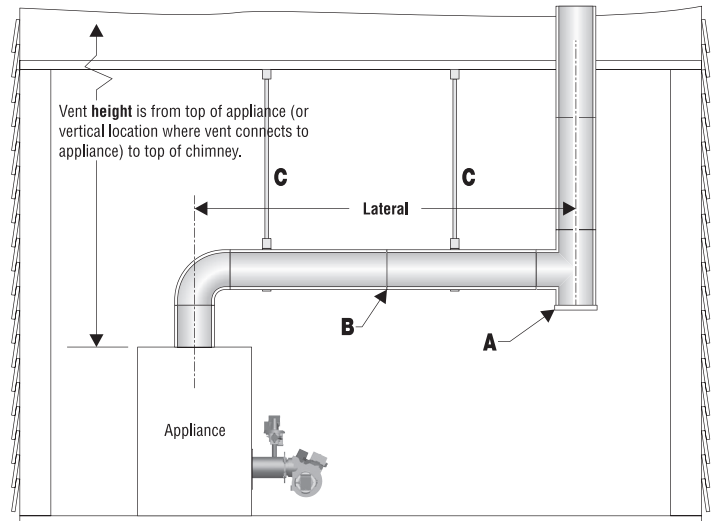

### Metal vent application

- A** Connect to vertical with tee, if possible, to provide inspection/cleanout opening in vent.
- B** Seal all joints and access openings tightly to prevent draft loss.
- C** Support vent pipe so no weight of vent connector rests on appliance.

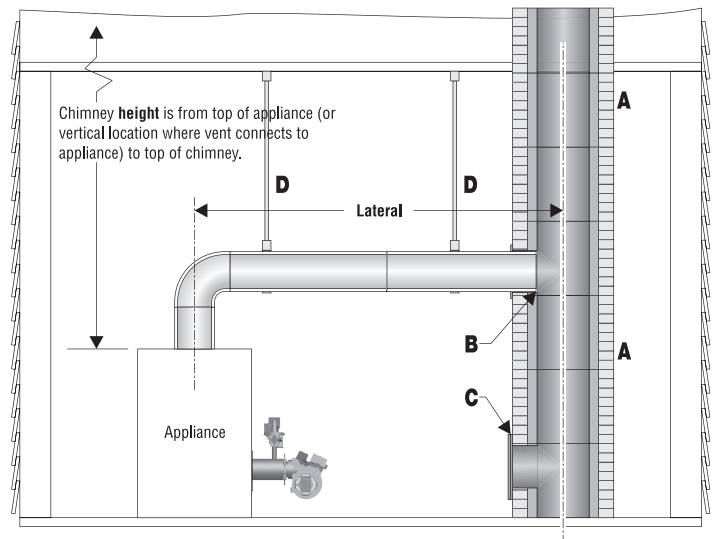

### Masonry chimney application

- A** Tile-lined interior masonry chimney only; with all tile and joints in good condition.
- B** Vent pipe should be almost flush, but **not extending into**, inside surface of liner.
- C** Seal all access openings tightly to prevent draft loss.
- D** Support vent pipe so no weight of vent connector rests on appliance.

30102

Where appliance instructions differ from this manual, follow the appliance instructions.

# 1. Prepare Site • Prepare Burner • Mount Burner (continued)

## Combustion air/ventilation openings

### General

**WARNING** Installing the burner/appliance in a space that does not provide enough air for combustion and ventilation can result in severe personal injury, death or substantial property damage. Follow all applicable codes and guidelines below to ensure space has sufficient air openings.

**WARNING** Exhaust fans and negative pressure conditions — Isolate the boiler room from areas subject to negative pressure. Size combustion air openings to ensure neutral air pressure in the boiler room whenever the burner operates.

**WARNING** Make sure the space provides enough ventilation to prevent overheating of the appliance, burner and controls. If there is risk of overheating, you must install ventilation air openings sized large enough to provide air for cooling the equipment. Failure to provide ventilation can result in severe personal injury, death or substantial property damage.

**WARNING** The space and combustion air supply must not contain corrosive contaminants, such as laundry products, paints, varnishes or other chemicals.

### Sizing air openings

Follow all applicable codes and the appliance instruction manual (when available) to size combustion air openings. Use the following guidelines when appliance instructions are not available.

- All air from inside building (building must be well-ventilated):  
Size air openings for a free area (after louver deduction) of at least 1 square inch per 1,000 Btuh input of all appliances in the space.
- All air through openings to outside:

### Locating air openings

Follow all applicable codes and the appliance instruction manual (when available) to size combustion air openings. Refer to Figure 2 when appliance instructions are not available.

### Free area estimating

When specific information on the free area of louvers is not available, estimate free area as:

- wood louvers — free area = area times 0.25.
- metal louvers or grilles — free area = area times 0.60.
- screens, when used must be no smaller than ¼ inch mesh.

### Motorized vent dampers

Wire the vent damper end switch to prevent operation of the burner until the air opening louvers are fully open.

### Combustion air/ventilation opening checklist

- Verify that openings are unobstructed.
- Verify that appliance space and air source spaces are free of:
  - Gasoline or other flammable liquids or vapors.
  - Combustible materials.
  - Air contaminants, such as laundry products, paint, thinner, varnish, etc.
- Confirm with user that the area will be kept free of these materials at all times.

### Verify clearances

- Verify that the burner/appliance will maintain all clearances to combustible walls or floor and all clearances required for service/maintenance as required in the appliance manual and applicable codes.

**Figure 2** Locating combustion air/ventilation openings

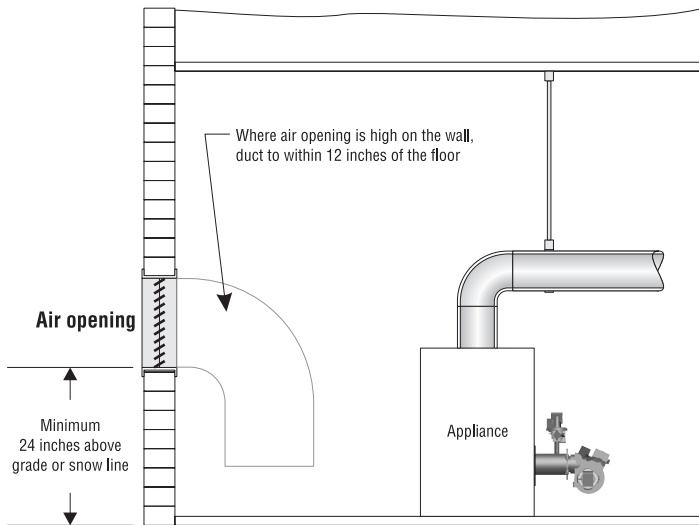

- A** Tile-lined interior masonry chimney only; with all tile and joints in good condition.
- B** Vent pipe should be almost flush, but *not extending into*, inside surface of liner.
- C** Seal all access openings tightly to prevent draft loss.
- D** Support vent pipe so no weight of vent connector rests on appliance.

30103

# 1. Prepare Site • Prepare Burner • Mount Burner (continued)

## Prepare the appliance

**WARNING** **Clean the appliance:** Clean the appliance thoroughly and seal all joints. Test all electrical components and verify the relief valve works (boilers only).

**Burner input:** Install a gas burner sized for the normal input rating of the appliance. Do not install a burner with a higher firing rate than the appliance rating. Do not install a burner with a firing rate more than 10% lower than the appliance rating. The appliance and vent system could be damaged due to condensation.

**Seal the appliance:** Seal all flue-gas containing joints. Seal all connections to the vent piping or breeching.

**Verify combustion chamber dimensions** comply with the minimum dimensions shown in Figure 3, page 7. Install or replace chamber liner if required by the appliance manufacturer. The burner must not extend into the combustion chamber. The end of the burner air tube must be within ¼" of the inside face of the chamber. If the space around the burner air tube is more than ¼", wrap the burner air tube with minimum 2300-°F-rated ceramic fiber blanket to seal off the gap.

**Repair or replace damaged appliance components.** Inspect the appliance thoroughly. Follow appliance manufacturer's guidelines for repair or replacement of any component found defective.

When cleaning the appliance or working with **ceramic fiber refractories or fiberglass insulation**, see **WARNING** on this page.

Failure to comply with the above could result in severe personal injury, death or substantial property damage.

## Prepare appliance for burner mounting

**WARNING** **Positive overfire pressure applications:** When firing with positive overfire pressure, do not exceed the pressure specified in the appliance manual.

Positive overfire pressure reduces maximum burner capacity. See Table 1 notes for estimated reduction in burner capacity with pressurized firing.

Failure to comply could result in severe personal injury, death or substantial property damage.

## Check bolt locations

Verify that the burner flange bolt layout matches that of the appliance. See page 19 for required dimensions and bolt locations.

## Ceramic fiber or Fiberglass insulation

**WARNING** Ceramic fiber materials, such as chamber liners, may contain carcinogenic particles (chrysothalites) after exposure to heat. Airborne particles from fiberglass or ceramic fiber components have been listed as potentially carcinogenic by the State of California. Take the following precautions when removing, replacing and handling these items.

**Avoid breathing dust and avoid contact with skin or eyes.** Wear long-sleeved, loose-fitting clothing, gloves and eye protection. Use a NIOSH N95 certified respirator. This respirator meets requirements for protection from chrysothalites. Actual job requirements or NIOSH regulations may require other or additional protection. For information, refer to the NIOSH website, <http://www.cdc.gov/niosh/homepage.html>.

**Ceramic fiber removal:** To prevent airborne dust, thoroughly wet ceramic fiber with water before handling. Place ceramic fiber materials in a plastic bag and seal to dispose.

**Avoid blowing, tearing, sawing or spraying** fiberglass or ceramic fiber materials. If such operations are necessary, wear extra protection to prevent breathing dust.

**Wash work clothes separately from other laundry.** Rinse clothes washer thoroughly afterwards to prevent contamination of other clothing.

### NIOSH First aid procedures:

Eye exposure — irrigate immediately

Breathing — fresh air.

Where appliance instructions differ from this manual, follow the appliance instructions.

# 1. Prepare Site • Prepare Burner • Mount Burner (continued)

## Prepare burner and components

**WARNING** Do not install or operate the burner if any component is damaged or if burner does not comply with the specifications of Table 1 and other guidelines in this manual.

### Combustion head/air tube configurations

- 301GAS burners are supplied with either an “B” or “C” head and air tube combination. The “B” head/tube is designed for the low range from 401 to 700 MBH. The “C” head/tube is for the high range from 550 MBH to 1,100 MBH.

### Air tube insertion length (UTL)

- Usable air tube length (UTL) is the distance from mounting flange to end of air tube. Verify that the end of the air tube will be flush with, or no more than ¼ inch short of, the inside of the appliance combustion chamber front wall when the burner is mounted. See Figure 3 and Table 1 for further information.

Figure 3 Chamber dimensions & tube configurations

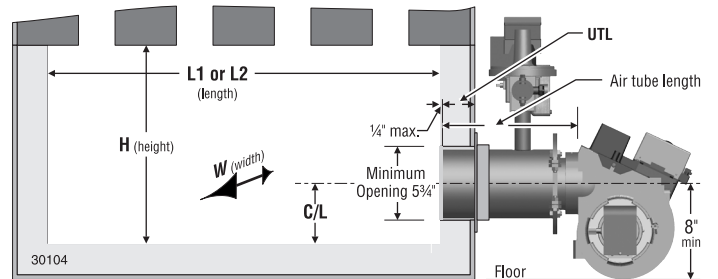

Table 1 Burner orifice sizing, air settings and minimum combustion chamber dimensions (see Figure 3)

Input Note 1	Burner orifice drill size Inches		Approximate air settings Notes 1 & 2		Air tube & Head	Minimum chamber dimensions Inches (Notes 3, 4, 5) (VC = min. diam. of vertical cylinder chamber)						UTL Air tube insertion length			
	Btuh	Natural gas	Propane gas	% open		Air shutter	C/L	L1	L2	W	H	VC	Nominal air tube length	UTL min.	UTL max.
401,000	7/16	11/32	20	Blank	B	6.0	20	24	15	13.5	17	Welded flange: Burners with <b>welded flange</b> have fixed usable tube length (UTL) set for the appliance application. Verify length is correct for the application.  Adjustable flange: Burners with <b>adjustable flange</b> : Usable tube length (UTL) varies with air tube length (see below).			
450,000	15/32	23/64	30	Blank	B	6.5	22	26	16	14.5	19				
500,000	31/64	25/64	35	Blank	B	7.0	23	27	16	15.5	20				
550,000	17/32	27/64	40	Blank	B	7.0	23	27	16	15.5	20				
			20	Center	C										
600,000	35/64	7/16	50	Blank	B	7.5	23	27	17	16.5	20				
			25	Center	C										
650,000	37/64	29/64	60	Blank	B	8.0	24	28	18	17.5	21				
			30	Center	C										
700,000	19/32	15/32	70	Blank	B	8.5	24	30	19	19.5	21				
750,000	5/8	31/64	40	Center	C	8.5	30	36	19	19.5	27				
800,000	21/32	1/2	50	Center	C	8.5	35	41	19	19.5	32				
850,000	11/16	33/64	60	Center	C	9.0	38	44	20	20.0	35				
900,000	23/32	17/32	70	Center	C	9.0	39	45	20	20.0	35				
950,000	25/32	35/64	80	Center	C	9.0	40	46	20	20.0	36				
1,000,000	13/16	9/16	65	None	C	9.5	41	47	21	21.0	37				
1,050,000	15/16	37/64	85	None	C	9.5	41	47	21	21.0	37				
1,100,000	1	19/32	100	None	C	10.0	42	48	21	22.0	38				

Note 1 Ratings:  
 • The maximum burner inputs at sea level are 700,000 Btuh for the “B” tube/head, 1,100,000 Btuh for the “C” tube/head.  
 • Altitude ratings: Reduce maximum capacity by 4% per 1,000 feet above sea level.  
 — Example: The maximum “B”-tube/head capacity at 5,000 feet altitude is 560,000 Btuh instead of 700,000, a 20% reduction.  
 Positive overfire pressure effects:  
 • Maximum burner input decreases with increasing overfire pressure.  
 • Assume a reduction in maximum burner input of approximately 5% at 0.1 inches w.c. and 10% at 0.2 inches w.c.  
 • You will have to increase the air band opening to compensate for the increased pressure.  
 • Follow the procedures given in this manual to check combustion with instruments to determine the correct air band setting.  
 • Never fire at a higher overfire pressure than recommended by the appliance manufacturer.

Note 2 Use this as the starting setting only. Adjust air band setting, if necessary, after performing combustion testing (see page 14).

Note 3 Some tested appliances may operate satisfactorily with dimensions less than the above.

Note 4 Horizontal cylindrical chambers — diameter must be no less than column “W” above  
 Horizontal stainless steel cylindrical chambers — diameter at least 1 to 4 inches larger than column “W” above.  
 VC is the minimum diameter for vertical cylindrical chambers (refractory or refractory-lined chambers only).

Note 5 A corbel may help heat transfer in a larger boiler or furnace, provided it is recommended by the appliance manufacturer.

# 1. Prepare Site • Prepare Burner • Mount Burner (continued)

## Inspect/correct flame rod/electrode

- Before installing the burner in the appliance, inspect the flame rod and electrode.
- Verify the dimensions shown in this page.
- If the flame rod or electrode is damaged or not in the correct position, follow the procedure below to access and adjust.

### To access the flame rod or electrode

1. If the burner is not installed in an appliance, you can inspect the flame rod and electrode from the front of the burner. To change the position of the flame rod or electrode, you must remove the combustion head/gas manifold assembly from the burner. See “D” thru “H” below.
2. To remove the combustion head/gas manifold assembly, you must disconnect the gas piping and swing the burner flange door open. See Figure 4, and proceed to:
  - a. Turn off all power to the burner and appliance before proceeding.
  - b. Close the manual gas valve on the gas supply line.
  - c. Disconnect the burner gas train union.
  - d. Remove the gas pipe at the burner air tube.
  - e. Remove the four nuts securing the burner hinged door flange.
  - f. Swing the burner open at the door flange.
  - g. Remove the two screws holding the gas manifold saddle to the air tube. (Save the gasket.)
  - h. Disconnect electrode and flame rod wires then slide the burner combustion head/gas manifold assembly out the end of the open air tube.
3. Position Electrode first — Make sure the electrode is placed according to the dimensions shown in Figure 6. To adjust the electrode, loosen the electrode clamp screw and slide/rotate into position. Tighten the electrode clamp screw after positioning. The shim rod welded in the clamp’s v-groove aligns the bracket when tightening.
4. Position Flame rod after setting electrode — Make sure the flame rod is located as shown in Figure 7. To adjust, loosen the flame rod clamp screw. Tighten the screw to secure the flame rod in place.
5. Replace the combustion head/manifold in the air tube.

**Figure 4** Removing combustion head/gas manifold

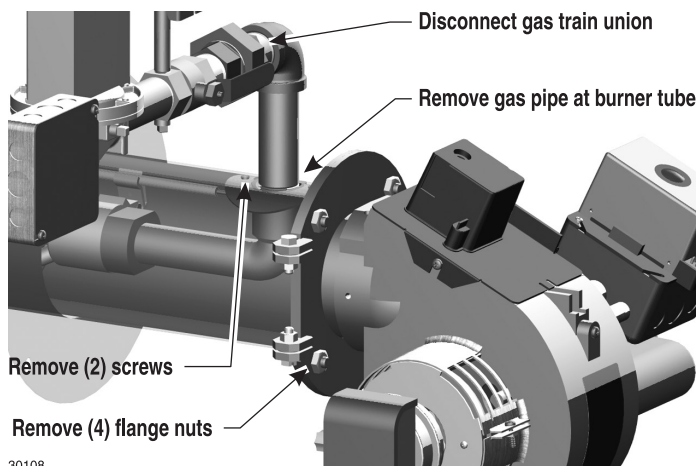

30108

**Figure 5** Combustion head

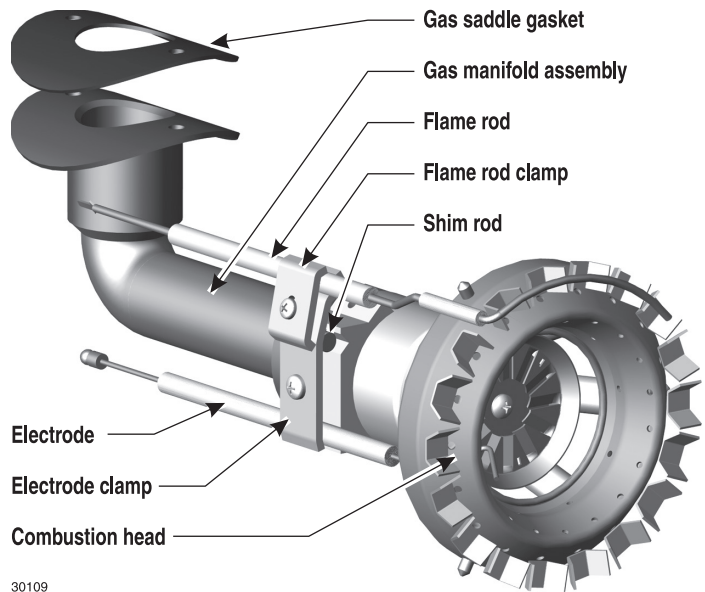

30109

**Figure 6** Electrode location

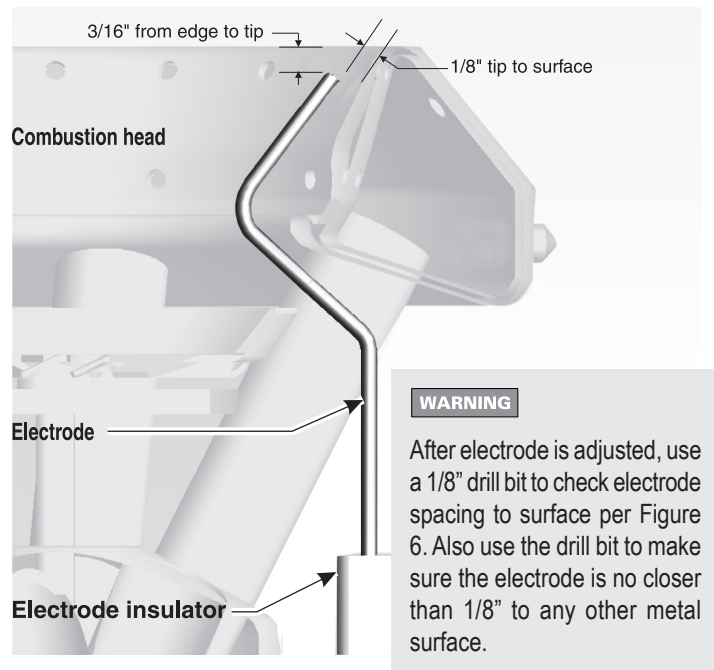

**WARNING**

After electrode is adjusted, use a 1/8" drill bit to check electrode spacing to surface per Figure 6. Also use the drill bit to make sure the electrode is no closer than 1/8" to any other metal surface.

**Figure 7** Flame rod location



30111

Where appliance instructions differ from this manual, follow the appliance instructions.

# 1. Prepare Site • Prepare Burner • Mount Burner (continued)

## Mount burner in appliance

- Verify appliance burner front plate dimensions and bolt locations.
- Slide gasket supplied with burner over end of air tube.
- Insert burner into appliance opening and bolt in place.
- Level the housing if necessary by loosening the set screws securing the housing to the air tube. Retighten the set screws.

## Inspect/redrill gas orifice

**WARNING** If the burner is installed, you must disconnect power to burner and close main manual gas valve before proceeding. Failure to do so could result in severe personal injury, death or substantial property damage.

**WARNING** In the state of Massachusetts, when lever-type gas shutoffs are used, they must be T-handle type only.

1. Turn off power to the burner/appliance before proceeding.
2. Close main manual gas valve in gas supply line to burner.
3. Disconnect the burner gas train union if the burner/gas train is installed. See Figures 8 and 9.
4. Locate the correct orifice drill size in Table 1, page 7 (or appliance manual). Then check actual orifice size using that size drill bit.
5. **If the gas orifice is smaller than required**, unscrew the orifice nipple from the elbow. Then redrill the orifice to the correct size. Replace the gas train, using only pipe dope listed for use with liquefied petroleum gases.
6. **If the gas orifice is larger than required**, remove the orifice nipple from the elbow. Obtain a replacement orifice nipple. If necessary, drill the correct orifice hole in the new orifice to the correct size.
7. Replace gas train. Seal pipe joints with a small amount of pipe dope. Use only pipe dope approved for use with propane gas.

Figure 8 Gas orifice location

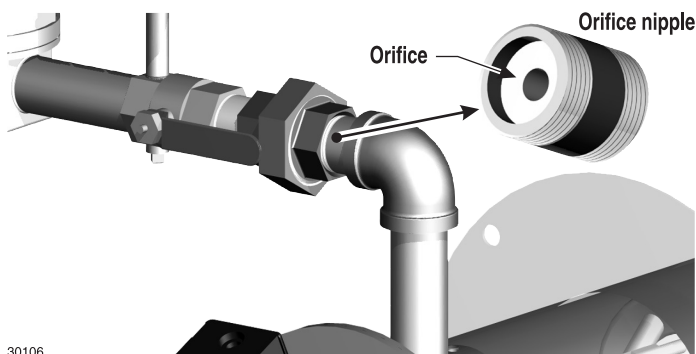

30106

## Install gas train on burner

1. The standard burner gas train is shipped fully assembled, with the piping disconnected at the gas train union. See separate instructions if installing an optional knocked down gas train.
2. Connect the gas train at the union (Figure 9).

**WARNING** To avoid damage to gas train components, do not hold components with a pipe wrench or overtighten. Use only a crescent wrench or other means. Failure to comply could result in severe personal injury, death or substantial property damage.

3. Connect the flexible conduit, pre-attached to the primary control J-box, to the gas train J-box, and attach the wires to the terminal strip inside the gas train J-box.
  - a. Match wire colors of the incoming wires to those pre-wired to the terminal strip inside the gas train J-box.
  - b. See the label in the burner junction box or the wiring diagram on page 11.

**NOTICE** Gas valve vent opening — If local codes require, install piping from vent connection to outside, sized and installed as required by codes. A vent limiting orifice is provided. Install in vent opening, if starts are hard, before piping to outside.

On a new burner “out of the box” the (supplied) **fixed bleed orifice is located in a small plastic taped to the V48 valve**. When the (supplied) fixed bleed orifice is installed in the 1/8" NPT vent opening of the V48 gas valve it slows down the opening of the diaphragm for smooth light offs. Use a #3 hex /Allen key to friction fit the orifice into the 1/8" NPT vent tapping.

There are two types of bleed orifices available: Fixed (supplied by Carlin - part # 99228S) and adjustable (available at wholesale). The recommended adjustable bleed orifice is a Honeywell 126590/U, it allows for the adjustments of how quickly the V48 valve completely opens. Adjustable bleed orifices should be used when there is a low pressure train or the (factory) distance has been extended between the V48 valve and the gas inlet to the burner.

Figure 9 Gas train installation

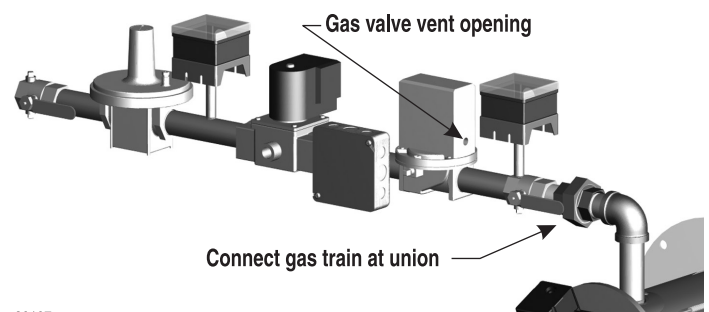

30107

## Inspect components and wiring

- Visually inspect all burner components and wiring.
- Verify that wiring is intact and leads are securely connected.
- Verify that all burner components are in good condition.
- Check gas pressure switch settings. Set the low gas pressure switch at manifold setting minus 50%. Set the high gas pressure switch at manifold setting plus 50%.

## 2. Install Gas Piping from Meter to Combination Gas Train

### Code compliance

The burner/appliance installation must comply with codes listed on page 2 and any other locally applicable codes.

### Piping from gas meter to burner

**WARNING** Connect from the gas supply to the burner gas train inlet using new, clean black iron pipe and malleable iron fittings only. Do not use copper, brass, cast iron or galvanized pipe or fittings. Provide support for gas piping. Do not rest the weight of the gas piping on burner gas train. Provide a support for the burner gas train. Apply pipe dope sparingly at all joints. Use only pipe dope listed for use with propane gas. Do not use pipe sealing tape. Do not hold the gas valve with pipe wrench. Use crescent wrench or other smooth-jawed device. Do not overtighten. Failure to comply with above could result in severe personal injury, death or substantial property damage.

1. If possible, install a new gas line directly from the gas meter. If you are using an existing gas line, verify it is clean and in good condition, and verify it is large enough to handle the load of all connected appliances.
2. When branching from a common gas line, do not tap off from the bottom of horizontal sections — only from the side or top.
3. Install a main manual shutoff valve, sediment trap and ground joint union near the burner combination gas valve connection as shown in Figure 10.
4. If the burner is installed inside an appliance jacket, install the main manual gas valve and sediment trap external to the jacket.
5. Size piping (or verify size) using Table 2. You will find additional information on gas line sizing in the National Fuel Gas Code, NFPA 54/ANSI Z223.1, or B149.1/B149.2 Installation Code for Canadian Installations.

Figure 10 Connecting gas supply piping to burner

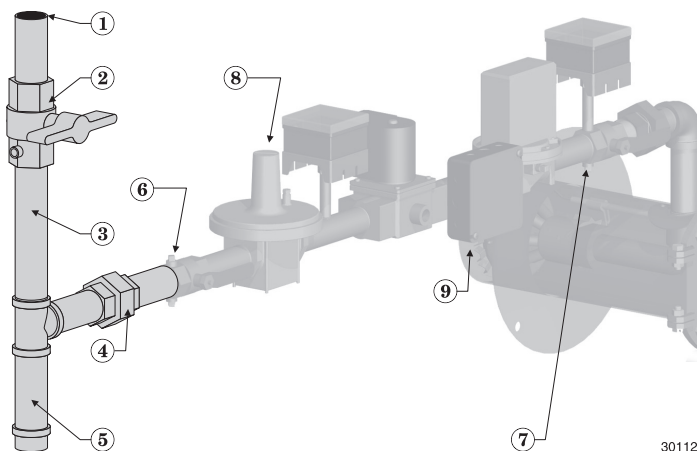

- |  |                               |
|--|-------------------------------|
| 1 Pipe to meter or branch  | 5 Sediment leg                |
| 2 T-handle main manual gas valve                                   | 6 Upstream pressure tap, 1/4" |
| 3 Use clean, burr-free black iron pipe and malleable iron fittings | 7 Outlet pressure tap, 1/4"   |
| 4 Ground joint union   | 8 Gas regulator access screw  |
|  | 9 Gas valve wire junction box |

Table 2 Capacities of black iron pipe, cubic feet gas/hour

<b>NATURAL GAS</b> Capacities in <i>Cubic feet per hour</i> for Schedule 40 metal pipe					
Pipe size (inches)	Total length of gas piping, from meter to burner connection (feet)				
	20	40	60	80	100
<b>Natural gas @ .60 specific gravity, pressure drop 0.3 in. w.c. (note 1)</b>					
1¼	730	500	400	350	305
1½	1,100	760	610	530	460
2	2,100	1,450	1,150	990	870
2½	3,300	2,300	1,850	1,600	1,400
<b>Natural gas @ .60 specific gravity, pressure drop 0.5 in. w.c. (note 1)</b>					
1	465	320	260	220	195
1¼	950	660	530	460	400
1½	1,460	990	810	690	620
2	2,750	1,900	1,520	1,300	1,150
2½	4,350	3,000	2,400	2,050	1,850

Note 1 For natural gas with specific gravity other than 0.60, consult National Fuel Gas Code, NFPA 54/ANSI Z223.1, or Canadian B149.1/B149.2 for correction factor.

<b>PROPANE GAS</b> Capacities in <i>Btu/h</i> for Schedule 40 metal pipe					
<b>Propane gas @ 1.5 specific gravity, pressure drop 1 psi</b>					
½	1,684	1,157	929	795	705
¾	3,521	2,420	1,943	1,663	1,474
1	6,632	4,558	3,660	3,133	2,776
<b>Propane gas @ 1.5 specific gravity, pressure drop 0.5 in. w.c.</b>					
1	735	506	411	348	308
1¼	1502	1043	838	727	632
1½	2308	1565	1281	1091	980

### Gas supply pressure — natural or propane

- Maximum supply pressure: **14 inches w.c.**
- Minimum supply pressure: **5 inches w.c.**

**WARNING** Do not expose the gas train to gas pressure in excess of 14 inches water column. Higher pressure could damage the valve seat, resulting in potentially hazardous condition. When pressure testing piping at higher pressures, disconnect burner from gas line before testing.

If the gas supply pressure can exceed 14 inches water column at any time, you must install a lockup type gas pressure regulator in the gas supply piping, ahead of the main manual gas valve installed at the burner.

### Test and purge gas line

Read WARNING above.

Pressure test and purge the line. Pressure testing should be done by the gas supplier or utility, following all applicable codes.

Where appliance instructions differ from this manual, follow the appliance instructions.

### 3. Wire Burner

#### Code compliance

The burner/appliance installation must comply with codes listed on page 2 and any other locally applicable codes.

#### General wiring requirements

**WARNING** Read and follow the guidelines below. Failure to comply could result in severe personal injury, death or substantial property damage.

**Electrical shock hazard** — Disconnect electrical supply to the burner before attempting to service.

**Electrically ground burner** — The burner must be grounded in accordance with local codes or, in the absence of local codes, with the National Electrical Code, ANSI/NFPA 70, or CSA C22.1/CSA C22.2 Canadian Electrical Code for Canadian installs.

**Label all wires** before removing for servicing. Wiring errors could result in unsafe appliance/burner operation.

**NOTICE** Read appliance manufacturer’s instructions completely before wiring burner.

The 60200FR control requires a constant 120 VAC power source from the appliance as well as power from the appliance limit circuit. See Figure 11.

**Check polarity carefully. If hot and neutral wires are reversed at appliance power source, the control will lockout on flame failure.**

If replacing any of the wire supplied with the burner, use minimum #18 AWG 125°C or better.

#### Verify power supply

1. The burner requires a 120 VAC/60 HZ/single-phase power supply, with at least a 10-amp fuse. The current draw will be (when equipped with typical motor and Carlin 41800 electronic ignitor) approximately:

Approximate amp draw	
<b>Motor →</b>	1/6 HP
During ignition	2.5 AMPS
Steady operation	2.0 AMPS

2. The 120 VAC power connections to the black and red/white wires of the 60200FR must be the same polarity **from the same power source**. DO NOT attempt to supply separate power sources. Check the power from the appliance with a voltmeter. Verify that the supply to the black and red/white wires are from the 120 VAC HOT side and that the power is no less than 102 VAC nor more than 132 VAC.

#### Checking burner flame signal

The 60200FR uses flame rectification to detect the flame. Because the grounded metal surface area near the flame rod is much larger than the surface of the flame rod, current flows through the flame more easily in one direction than the other. This causes an AC voltage applied to the flame rod to result in a DC current. (Note that, if the flame rod should touch a grounded metal part, the current would be AC, not DC, and the control would not sense flame causing a flame failure.)

The minimum flame signal needed to satisfy the 60200FR sensing circuit is 0.8 microamps. The control will register flame failure at any lower signal.

Figure 11 Wiring diagram — 301GAS burner with 60200FR primary control

Commercial Gas Train 120V

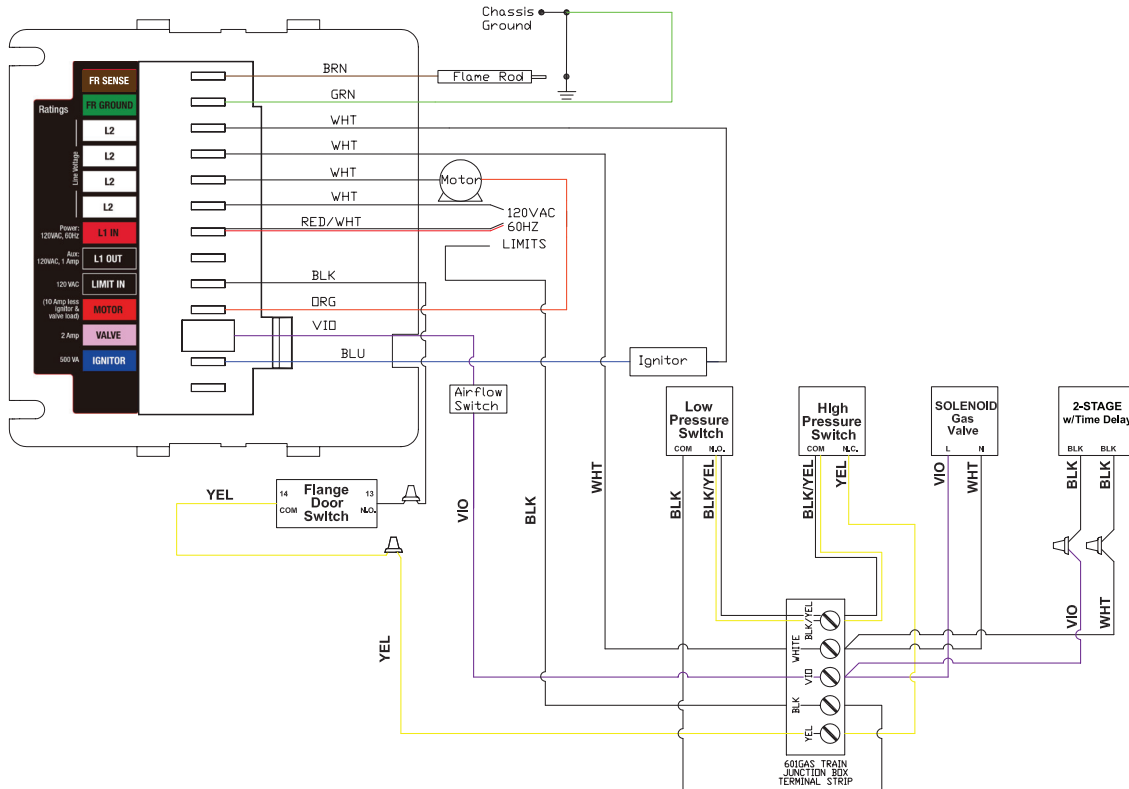

Ventless Commercial Gas Train 120V and Massachusetts Commercial Gas Train 120V

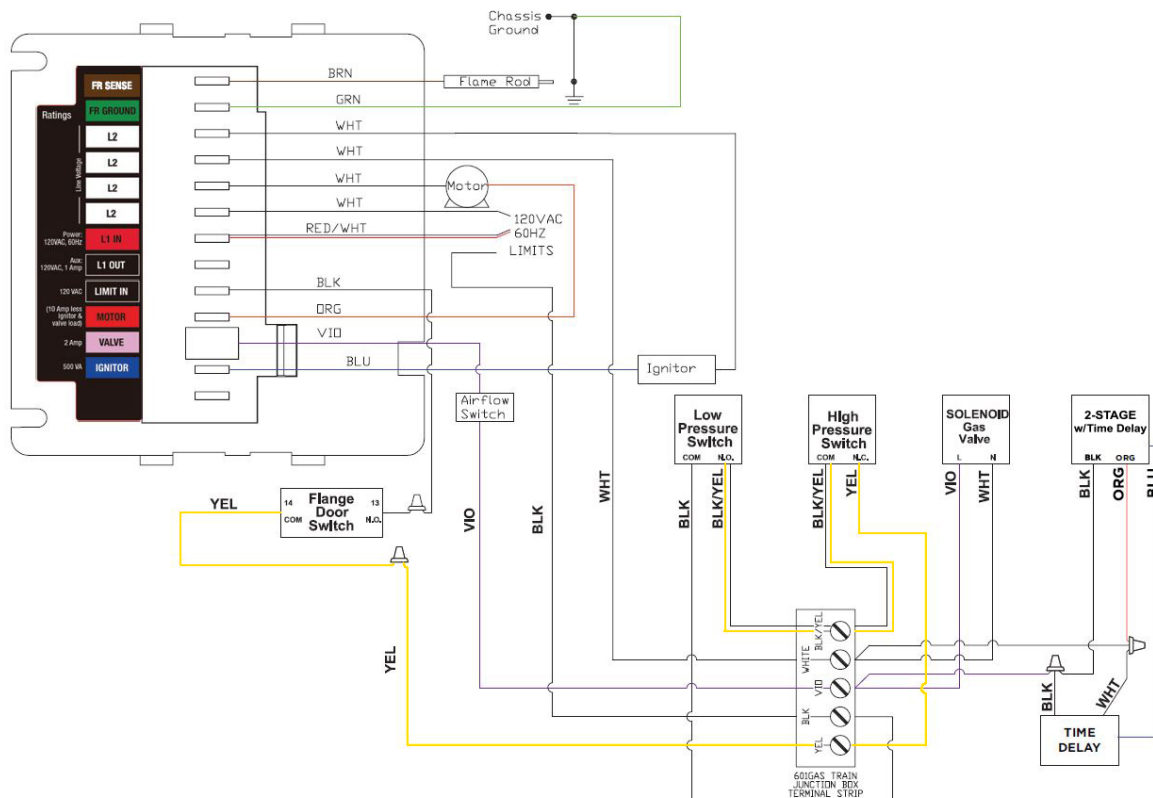

Where appliance instructions differ from this manual, follow the appliance instructions.

## 4. Check System • Start-up Burner/Appliance

### Inspect/check system

Before starting the burner and appliance, verify the system has been installed as directed by this manual and the appliance instructions.

#### Check gas piping for leaks

**WARNING** Disconnect the burner from the gas supply line if gas line test pressure will exceed 14 inches w.c. Exposing the burner gas train to pressure higher than 14 inches w.c. can damage the valve seat, resulting in potentially unsafe operation.

You can usually test the gas piping by allowing the line to fill with gas to main regulator outlet pressure.

1. Shut off gas flow to all equipment connected to the meter.
2. If test pressure will be less than 14 inches w.c., close the gas train manual gas valve. If test pressure will be higher than 14 inches, remove the burner gas train from the gas line by shutting off the main manual gas valve installed near the burner (per Figure 10, page 10) and disconnecting the ground joint union. See WARNING above.
3. Watch the gas meter dial. For a one half cubic foot per revolution dial, there should be no movement of the dial for at least 5 minutes. For larger volumes per revolution, increase this time proportionately.
4. If you detect a gas leak, locate the leak with a soap suds mixture and repair it. Then test the system for leaks again.

**WARNING** Do not test for leaks with an open flame. And do not use oxygen as a test gas. Either of these could cause an explosion, resulting in severe personal injury, death or substantial property damage.

#### Bleed gas line

Purge all air from the gas line. Purge to outside of the building, NEVER into the appliance or burner.

#### Leak test near-burner gas piping

If piping near burner has not already been pressure tested, open main manual gas valve on supply to burner and smell around area for any signs of gas. Apply a soap suds mixture to all gas piping joints near burner and check for any leaks. If any leaks appear, repair before proceeding and retest.

#### Set burner air band

See Figure 12. Loosen air band locking screw. Then rotate band until it is open to the setting given in Table 1 page 7. Tighten air band locking screw. The Table 1 setting will probably be satisfactory without change. If the combustion test indicates a need for more or less air, however, you will have to adjust the band accordingly.

#### Check burner and primary control

Inspect burner thoroughly. Verify that hinged ignitor cover plate is closed and screw is tight. Verify all wiring is in place and all components are secure and in position.

Figure 12 Air band adjustment

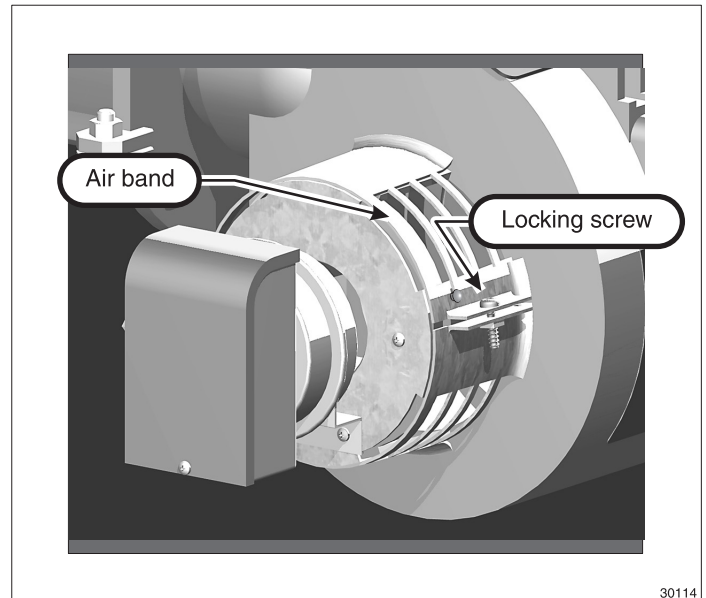

**WARNING** Do not start the burner if you smell gas or if there may be gas present in the appliance combustion chamber, appliance or the vent system. An explosion could occur, causing severe personal injury, death or substantial property damage.

**WARNING** During initial start-up, you must be constantly alert for emergency conditions such as fuel leaks, electrical malfunctions, etc. Familiarize yourself with the location of manual shutoff valves and switches so you can quickly use them if needed.

**WARNING** If the burner fails to ignite, NEVER attempt to manually bypass the normal sequence of the control, which provides purging of the combustion chamber.

#### Verify flame failure Lockout of 60200FR control

1. Install a hose barb fitting in the manual gas valve pressure tap (item 10a, page 3) and connect with a hose to a U-tube manometer.
2. Close the main manual gas valve and turn the combination gas valve knob to ON.
3. Turn on power to appliance and set appliance limit(s) to call for heat.
4. Burner motor will start. The 60200FR will run for its prepurge timing, then start the ignitor. Approximately one second later, the gas valves will open. (The manometer should show almost no pressure, because the main manual gas valve is closed.)
5. After the Trial for Ignition Period, the 60200FR will lockout and turn on the red LED. The ignitor will shut off and the gas valve will close. Turn off power and set controls to stop call for heat.
6. If Lockout does not occur, replace the 60200FR control.

## 4. Check System • Start-up Burner/Appliance (continued)

### Programming and Setup – 60200FR

#### Definitions:

**Call for Heat (C.F.H.):** TT on + Limit In on + BV on + CO on

**Pre-Purge:** Time period the motor is on prior to T.F.I.

**Trial for Ignition: (T.F.I.):** Burner Flame Establishing period

**Post-Purge:** Time period the motor is on after a Call for Heat has been satisfied

**Post-Purge Interrupt:** If selected is Time at which the 120 second Post-purge will be interrupted if a C.F.H. occurs during the Post-purge.

**Allowed Recycles:** Number of Recycles allowed during a single C.F.H. prior to lockout due to flame loss.

**TT Used:** Select “NO” when not using TT, select “YES” when using TT

**Baseline Reset:** Resets the baseline statistics used by the fault history

**Factory Default:** Resets ALL settings to the “Factory Defaults”

Pre-Purge*	T.F.I.*	Post-Purge*	Post-Purge Interrupt*	Allowed Recycles	TT Used	Reset Baseline	Factory Default
		120					
		60					
90		30					
30		15		3			
10	6	10	60	1	Yes	Yes	Yes
0	4	0	Never	None†	No	No	No

Shaded box = default settings

\*In seconds

†MA code (“N” models) are non-recycling and will lock out on flame failure

**WARNING** Do not start the burner if the combustion chamber contains gas.

### Button Functions – 60200FR

#### Reset

1. Return to Standby from other operating states. Press for ½ second
2. Reset control from Lockout. Press for 1 second
3. Reset control from Latch-up. Press for 30 second

#### Display Control

##### ESC / ◀

- Display previous Operating State from Operating screen.
- Exit Log or Setup screen to Operating screen with 3 second press.
- Scroll through recent fault in Log screen.
- Scroll to previous parameter in Setup screen.
- Reject parameter change from Setup screen. Displays UNCHANGED on line 2 then after 2 sec, displays parameter with unchanged value.

##### DN / ▼

- Display Time on line 2 of Operating screen.
- Scroll down when in Log or Setup screen.

##### UP / ▲

- Display Flame Rod – μAmps on line 2 of Operating screen.
- Scroll up when in Log or Setup screen.

##### ENTR / ▶

- Display status/fault messages on line 2 from Operating screen.
- Move to less recent fault in Log screen.
- Move to next parameter in Setup screen.
- Accept parameter change from Setup screen. Displays ENTERED on line 2 then after 2 sec, displays parameter with changed value.

##### UP / ▲ & ENTR / ▶ for 3 seconds

- Enter Setup screen.

##### DN / ▼ & ENTR / ▶ for 3 seconds

- Enter Fault History screen.

##### DN / ▼ & UP / ▲ for 3 seconds

- Enter Diagnostic screen to display Load Current sensed and Line voltage.

Where appliance instructions differ from this manual, follow the appliance instructions.

## 4. Check System • Start-up Burner/Appliance (continued)

### Screen Information – 60200FR

The first line on the LCD screen shows the controls Firmware version at power up then will show the operating state. The screen turns off after 30 minutes and will turn on if the control goes to lockout or if any button is pushed.

**Power On:** Open all manual gas valves. Close the line switch. The screen displays the firmware version for 5 seconds

- “Version” • Display program version info for 5 seconds
- “Startup” • 3 sec of self-tests to verify internal operation, including a flame rod calibration (when the circuit looks at the flame rod signal at standby and uses this value to compare to when the control knows that the flame should be present). Once the tests pass, the control goes to “Standby”
- “Standby” • Normal state, wait for a CFH.  
• If fault message “BV Switch Open” or “CO Switch Open” is displayed, control will remain in standby even if there is a call for heat

**Call for Heat (CFH):** Set the Thermostat (TT) to Call for Heat, The BV, CO and Limit In must be closed to initiate a call for heat

- “Pre-Purge” • Turn on the burner motor  
• Motor on, Ignitor & Valve off
- “Pre-Ignition” • Ignitor turns on to establish spark prior to the gas valve(s) opening  
• Motor on, ignitor on, valve off
- “Trial for Ignition” • Motor on, Ignitor on, Valve(s) on  
• The ignitor turns off at the end of the TFI time and the flame rod must sense flame. Lockout if no flame detected
- “Flame Proven” • Maintain the burner on until the CFH is satisfied  
• Motor on, Ignitor off, Valve(s) on
- “Post-Purge” • Enter from Flame Proven when the CFH is satisfied.  
• TT or HV-Limit open.  
• Or if flame is lost during flame proven  
• Motor on, Ignitor off, Valve(s) off
- “Recycle” • Occurs on flame loss in flame proven  
• Motor off, Ignitor off, Valve(s) off for 60 sec. or lockout if the recycle limit has been reached (see setup)
- “Lockout” • Motor off, Ignitor off, Valve off, Alarm on  
• No flame detected at the end of TFI  
• Flame is detected during Pre-purge, Pre-ignition or Post-purge  
• CO input not detected during Pre-purge, Pre-ignition, TFI or Post-purge  
• BV input not detected after 30 second delay during Pre-purge, Pre-ignition, TFI or Post-purge  
• Motor, ignitor or valve relay weld detected  
• If the control is miswired causing voltage to be detected on the outputs terminals, motor, ignitor or valve, when not expected  
• Recycle limit count has been reached

When a lockout occurs, the screen turns on, the fault icon flashes and a fault message is displayed. The screen will cycle every 4 seconds between 2 displays, one giving the fault message and one giving the amount of time in the lockout state. For example, if the cause was loss of the CO input the fault icon would flash and the message would read “CO detected.” After 4 seconds, the time in the lockout state “secs or mins” will be displayed. This cycle will continue until the fault is resolved.

<i>Fault Message</i>	<i>Possible causes</i>	<i>Fault Message</i>	<i>Possible causes</i>
NO FLAME	No flame detected. Cause unknown.	FLAME IN PREPurge	Flame detected in prepurge
RECYCLE LIMIT	Exceeded “Recycles” setpoint limit	NO MOTOR POWER	Motor has no power (no 120volts present when there should be)
MOTOR POWERED	Motor relay welded or miswired	NO IGNITOR POWER	Ignitor has no power (no 120volts present when there should be)
IGNITOR POWERED	Ignitor relay welded or miswired	NO VALVE POWER	Valve has no power (no 120volts present when there should be)
VALVE POWERED	Valve relay welded or miswired	FLAME IN PREIGN	Flame detected in preignition
CO SWITCH OPEN	CO switch detected open indicating CO detected	FLAME DETECTED	Flame detected in postpurge or recycle
BV SWITCH OPEN	BV switch detected open after 30 second delay indicating a blocked vent		

To Reset from Lockout, press and hold the reset button for 1 second

- “Latchup” If the control locks out 3 times during a single call for heat, latch-up occurs. The control may be reset from latchup by holding the reset button down for 30 seconds, unless in permanent latchup.  
A permanent latchup occurs when a relay weld is detected and cannot be corrected. When this occurs, the display will read “Latchup Replace Control”.

**WARNING** Should overheating or an emergency occur, immediately:

- Shut off main manual gas valve.
- Shut off control switch to burner.

Under some circumstances power should remain on for circulating blowers or other equipment. Determine proper response before attempting start-up.

If burner fails ignition on several attempts, close gas valve and use burner blower to purge appliance before restart.

**WARNING** Do not start the burner if the combustion chamber contains residual gas. Allow gas to disperse.

## 4. Check System • Start-up Burner/Appliance (continued)

### Operating and Fault History – 60200FR

#### The 60200FR stores operating history

The first line contains the parameter listed below.

The second line contains the Value and Units if appropriate.

Lines starting with “Total” are not reset by Baseline Reset.

All other lines are reset using “Reset Baseline” setpoint.

#### “Fault Cycles”

- Number of fault cycles in log (50 max, then oldest is discarded)

#### “Total Cycles”

- Total Number of CFH cycles since control was put into service

#### “Total Run Time” (Motor on)

- Total Motor on time since control was put into service

#### “Total Burn Time” (Valve on)

- Total Valve on time since control was put into service

#### “Total On time”

- Total time since control was put into service

#### “Baseline time”

- Elapsed time since baseline was reset

#### “Max Line Volts”

- Highest line volts recorded since baseline reset

#### “Min Line Volts”

- Lowest line volts recorded since baseline reset

#### “Recycles”

- Total Recycles since baseline reset

#### “Run Time” (Motor on)

- Total Motor on time since baseline reset

#### “Burn Time” (Valve on)

- Total Valve on time since baseline reset

#### “CFH Cycles”

- Number of CFH cycles since baseline was reset

#### The 60200FR stores information from the last 50 fault cycles in a fault log with 1 being the latest fault

#### Fault Message

- The message that accompanied this fault
- If it was a Lockout message, the cycle is faulted

#### End State

- The last operating state before returning to Standby
- If not Post Purge or Flame Proven, the cycle is faulted

#### Flame Rod $\mu$ A

- The FR current on entry to Lockout or Standby
- If the FR current is outside its limits, the cycle is faulted

#### Line Volts

- Running average of detected Line Volts at end of CFH cycle
- If <102 or >132, cycle is faulted

#### Motor Current

- “ - ” if current has not been determined yet
- “Ok” if current is known and above limit
- “Low” if current is known and below limit  
Low current causes the cycle to be faulted

#### Ignitor Current

- “ - ” if current has not been determined yet
- “Ok” if current is known and above limit
- “Low” if current is known and below limit  
Low current causes the cycle to be faulted

#### Valve Current

- “ - ” if current has not been determined yet
- “Ok” if current is known and above limit
- “Low” if current is known and below limit  
Low current causes the cycle to be faulted

#### Recycle

- “Yes” if a recycle occurred in CFH cycle  
A recycle causes the cycle to be faulted
- “No”

#### Run time

- Time motor output is on during this cycle

#### Burn time

- Time valve output is on during this cycle

#### CFH Cycle, enter at this row on column change

- The CFH cycle during which this fault occurred
- “1” if first cycle after baseline was reset

Where appliance instructions differ from this manual, follow the appliance instructions.

## 4. Check System • Start-up Burner/Appliance (continued)

### Status Icons – 60200FR

#### Line 1 Inputs

##### “POWER”

- On if 120 VAC power detected
- Flash if Voltage is over 132 VAC or less than 102 VAC

##### “HV-LIM”: High Voltage Limit string input

- On if an input detected on the High Voltage Limit input terminals

##### “BV”: Blocked Vent, Low Voltage Limit string input

- On if BV input detected on the Low Voltage Limit input terminals

##### “T-T”: Thermostat input

- On if the T-T current is above the TT closed threshold
- Turn on if T-T used “NO” is selected

##### “FLAME”: Detected using Flame Rod

- On if DC uAmps in flame rod is at or above the flame detect threshold  $>0.8\mu\text{A}$

#### Line 2 Outputs

##### “FAULT”

- Fault detected, alarm output on. Always flashes when activated

##### “MOTOR”

- On with Motor output
- Flash if running and Low current detected
- Flash if suspected motor fault

##### “IGNITOR”

- On with Igniter output
- Flash if running and Low current detected
- Flash if suspected Igniter fault

##### “VALVE”

- On with Valve output
- Flash if running and Low current detected
- Flash if suspected Valve fault

## Service & Troubleshooting – 60200FR

### Burner (control) will not come on

#### No power to control

- Check line voltage to the control (at least 102 VAC).
- Check all electrical connections.

#### Control is in lockout

- Press the reset button for 1 second.

#### Other no start problems

- Line voltage  $<90$  VAC. Check line voltage.  $>132$  VAC
- Motor relay welded. If valve/ignitor has no voltage, and line voltage OK, the issue is a welded motor relay. Replace the control.
- Reversed 120 VAC polarity – make sure hot and neutral lines are not reversed on incoming lines.
- Check T-T, BV, CO and HV limit inputs.

### Repeated flame failures

#### Check for:

- Excessive airflow or draft causing flame to leave burner head- check for proper air band setting and draft.
- Excessive back pressure causing flame to be erratic – check appliance and flue for sooting/plugging.
- Defective flame rod assembly.

#### Control locks out at end of TFI

#### Check for:

- No gas to burner – check gas supply. Verify gas pressure is no higher than allowed for gas valve (usually 1/2 psig or 14" water column).
- Shorted electrodes (shorted to burner head or diffuser) – inspect for cracked porcelain and replace as needed.
- Poor spark – check electrode spacing and condition per burner manual. Replace or realign if necessary.
- Airflow too high – check air band setting.
- Ignitor module defective – replace if no spark.
- Check wiring connections.
- Flame rod shorted to ground or defective.

### FROZEN PIPES/WATER DAMAGE

*This is not a freeze protection device.* Suitable freeze protection monitoring or other precautions are recommended to protect against ruptured pipes/water damage caused by fuel outage, safety related fault conditions or equipment failure.

## 5. Perform Checkout Procedures • Fill Out Certificate

### Installer/servicer

#### Please check off and fill in certificate

- After completing start-up and testing or service, fill out the certificate on page 26.

**WARNING** Should overheating or an emergency occur, immediately:

- Shut off main manual gas valve.
- Shut off control switch to burner.

Under some circumstances power should remain on for circulating blowers or other equipment. Determine proper response before attempting start-up. If appliance fails ignition on several attempts, close gas valve and use burner blower to purge appliance before restart.

### Preparation before checkout

- Burner/appliance installed per appliance instruction manual?
- Burner components verified against Table 1, page 7?
- Burner/appliance installed per all applicable codes?
- Installation site has adequate ventilation openings and vent system?
- Gas supply line in good condition and sized correctly?
- All gas line joints sealed with pipe dope listed for use with liquefied petroleum gases?
- Gas supply pressure to gas valves checked?
- Regulator installed if pressure can exceed 14 inches w.c.?
- Air purged from gas line?
- Gas piping checked for leaks?
- Wiring installed per burner manual and appliance instructions?
- Burner inspected and primary control flame failure lockout checked?
- Start-up sequence performed (page 13)?

### Make final burner adjustments

#### Check for leaks in gas piping

- Smell around burner to make sure there is no gas leak in near-burner piping. Verify integrity of gas line joints between combination gas valve and burner gas inlet tapping using soap suds mixture.

#### Check/adjust gas valve outlet pressure

- With burner running, check manometer reading for combination gas valve outlet pressure. Adjust valve regulator if necessary so the reading is 3.5 inches w.c. for either natural gas or propane gas.

### Make final burner adjustments (continued)

#### Inspect flame

- Look at flame through appliance observation port. The flame should be a soft blue with well-defined orange and yellow tips for natural gas, or well-defined yellow tips for propane gas. (If you make air or gas pressure changes later, inspect the flame again.)

#### Check the firing rate

- Natural gas only — Turn off all other gas appliances connected to the gas meter. Use a stopwatch to time the number of seconds for a flow of one cubic foot of gas (two revolutions for a one half cubic foot per revolution dial, for example). You will also need to know the gas heat content in Btu per cubic foot. Determine the actual input from: INPUT = (3600 x Btu per cubic foot) ÷ (number of seconds for one cubic foot), for firing rate in Btuh. For example, for 1050 Btu per cubic foot natural gas, with meter timed at 15.1 seconds for one cubic foot of gas: INPUT example = (3600 x 1050) ÷ (15.1) = 250,500 Btuh. Firing rate should be within ± 5% of rated input for the appliance. Adjust the combination gas valve pressure regulator if necessary to obtain the correct firing rate. Valve outlet pressure must not be lower than 3.2 inches w.c. nor higher than 3.8 inches w.c.
- For propane gas, contact your propane supply for procedure to verify firing rate.

### Check combustion using instruments

**WARNING** Do not attempt to confirm combustion simply by inspecting the flame visually. You must use combustion test instruments. Failure to properly verify/adjust combustion could allow unsafe operation of the burner, resulting in severe personal injury, death or substantial property damage.

- Insert a test probe into appliance vent outlet to sample flue products. The results should show CO<sub>2</sub> or O<sub>2</sub> as follows:

Fuel	CO <sub>2</sub>		O <sub>2</sub>	
	Minimum	Maximum	Maximum	Minimum
Natural Gas	8.5%	10.0%	6.2%	3.5%
Propane Gas	9.5%	11.2%	6.0%	3.5%

- If the combustion results are outside the range above, and the firing rate of the burner is within 5% of rated input, open or close the air band until the CO<sub>2</sub> (or O<sub>2</sub>) are acceptable.

**WARNING** After CO<sub>2</sub> (O<sub>2</sub>) tests are completed satisfactorily, measure flue products for carbon monoxide (CO) concentration. The CO must not exceed 50 ppm adjust to “air free”, or other if specified by local codes.

- Check overfire pressure in the appliance. Refer to the appliance manual for recommended reading and barometric damper instructions for proper setting of damper, when used.

Where appliance instructions differ from this manual, follow the appliance instructions.

## 5. Perform Checkout Procedures • Fill Out Certificate (continued)

### Verify burner/appliance operation

#### Check burner/appliance/controls operation

- Test operating and limit controls on appliance as specified in appliance instruction manual.
- Check operation of the 60200FR primary control by forcing Latch-up (three consecutive lockouts during the same call for heat): Close the main manual gas cock. Temporarily jumper the low gas pressure switch. Then cycle the burner. Press the reset button to reset when the 60200FR control locks out on flame failure. Do this two times and the control should enter Latch-up. See page 13 to reset control. Remove the jumper from the low gas pressure switch.

- Check the airflow switch

Cycle the burner off with the appliance controls. Then turn off power to the appliance. Remove both of the sensing lines from the airflow switch by loosening the plastic sealing nuts and pulling the aluminum sensing tubes out of the socket.

With the sensing line removed, turn on power to the appliance and set the controls to call for heat. Watch the manometer on the manual gas valve outlet pressure tap. After the control performs its pre-purge, it will try to turn on the gas valves. The gas valves should not open with the airflow sensor line removed. Set the controls to stop the call for heat and turn off power to the appliance. If the airflow switch operates correctly (gas valves don't open), continue with normal operation. If the airflow switch fails to operate correctly, replace the switch and retest.

#### WARNING

NEVER attempt to adjust the air pressure switch setting. This could allow unsafe operation of the burner, resulting in potential of severe personal injury, death or substantial property damage.

- Check gas pressure switches

- High gas pressure switch —

Cycle the burner off with the appliance controls and turn off power to the appliance/burner.

Attach a manometer to the manifold-side manual gas valve test port.

Turn on power and cycle the burner on with the appliance controls.

Measure the manifold gas pressure with the manometer.

Set the high gas pressure switch to a pressure less than actual manifold pressure. The high gas pressure switch should shut the burner down. Replace the switch if necessary.

Turn off power to the appliance/burner; remove the manometer and replace the plug in the gas valve test port.

- Low gas pressure switch —

Cycle the burner off with the appliance controls and turn off power to the appliance/burner.

Close the main manual gas valve.

Cycle the burner on.

The low gas pressure switch should shut the burner down. Replace the switch if necessary.

Turn off power to the appliance/burner.

Open the main manual gas valve.

- Check flange door switch

Cycle the burner off with the appliance controls and turn off power to the appliance/burner.

Remove the nuts securing the hinged flange and swing the flange open.

Attempt to cycle the burner with the appliance controls.

The flange door switch should prevent the burner from operating. Replace the switch if necessary.

Close the flange door and replace the nuts.

#### Verify burner operation

- Start and stop the burner several times, allowing the primary control to sequence through normal operation. Verify correct operation of burner and controls throughout, including the burner door switch and high and low gas pressure switches.

#### Verify vent system operation

- Verify vent is operating correctly and flue products are properly exhausted from building.
- Check operation of barometric damper and spill switch.
- If the building contains any exhaust fans or conditions that could affect vent performance, check burner/appliance/vent operation with exhaust fans (or other conditions) operating.

#### Prepare the burner for normal operation

- Cycle burner off with appliance controls. Then turn off power to the appliance.
- Close the main manual gas valve.
- Verify all components and wires are in place and burner is ready for operation.
- When all tests and checks are completed, restore the burner and appliance to normal condition for operation.
- Start the burner again to verify proper operation before leaving.

#### Train the user

- Train the user to operate the burner and appliance under normal conditions. Explain procedure to shut down burner/appliance when required.
- Review the user information manual (and the appliance instructions) with the user.
- Verify the user is aware of all procedures specified in the manual.
- Verify user will not store or use combustible liquids or materials or contaminants in the vicinity of the burner/appliance.

## 6. Maintenance and Service Procedures

### Annual start-up & service

**WARNING** This burner should be started and serviced at least annually by a qualified service technician. Failure to properly maintain and service the burner could result in severe personal injury, death or substantial property damage.

**WARNING** Turn off power to appliance and close main manual gas valve when servicing burner. See warnings on page 2 and elsewhere in this manual regarding correct procedures. Failure to comply could result in severe personal injury, death or substantial property damage.

#### Annual start-up and service procedures

- Discuss burner/appliance operation with user to determine any problems that may have occurred during the previous season and to verify user is aware of proper operation and care of the burner/appliance.
  - Turn off power to appliance and close main manual gas valve.
  - Remove the burner from the appliance and inspect the combustion head assembly, ignitor electrode and flame rod (see page 8). Adjust if necessary as described on page 8.
- NOTICE** If the air tube or combustion head needs to be cleaned, clean with a vacuum cleaner with brush attachment with the combustion head assembly assembly out of the burner.
- Verify that the hinged ignitor cover plate is closed and the screw is tight.
  - Verify that the air tube flanged door is securely closed and the bolts are tightened.
  - Check the burner flange gasket. It must be in good condition. Replace gasket on burner flange and mount burner in appliance, securing to mounting studs.
  - Perform the complete checkout procedures of pages 12 through 15, including system inspection and checks.

### Maintenance/service procedures

#### Cleaning blower wheel

1. The blower wheel accumulates dust and debris from normal operation. You will need to clean the wheel blades periodically to prevent reduction in airflow. To clean blades, remove the two bolts securing the motor to blower housing.
2. Slide the motor out and rotate to remove and access blower wheel.
3. Use a brush and vacuum to clean each blade and the blower housing interior.
4. Replace motor/wheel in blower housing and secure with the two bolts.
5. Push wire slack back into junction box.

#### Replacing blower motor or wheel

1. If either the blower wheel or motor must be replaced, remove the two bolts securing the motor to housing.
2. Disconnect the motor wires in the burner junction box.
3. Loosen the Allen screw securing the blower to the motor shaft and remove the wheel.
4. When assembling the replacement assembly, slide the wheel onto the motor shaft and use feeler gauges to set a space of 1/8 inch between the blower wheel and the motor face.
5. Replace the motor/wheel assembly in the housing, wire the motor leads and secure the motor with the two bolts.

#### Motor maintenance

The motor is constructed with permanently-lubricated bearings, and requires no oiling. Should you replace the original motor with another type of motor, occasional oiling may be required, depending on motor design and manufacturer's recommendations.

**WARNING** Any time you replace a component or disassemble any part of the burner for service/maintenance, perform a complete operational test after reassembly to verify the burner operates correctly. Failure to verify operation could result in severe personal injury, death or substantial property damage.

Where appliance instructions differ from this manual, follow the appliance instructions.

## 7. Troubleshooting

Problem	Possible cause	Corrective action
<b>WARNING</b>		These procedures must only be performed by a qualified service technician. Use care when performing tests on electrically or mechanically live parts. Disconnect power to burner/appliance and close main manual gas valve when removing components for service. Failure to comply could result in severe personal injury, death or substantial property damage.
Burner motor will not start	120 VAC power circuits	Check voltage and polarity at entrance to appliance and burner. Check fuse or breaker protecting circuit. Check appliance limit circuit — are controls calling for heat? Check electrical connections.
	Primary control is in Lockout	When a lockout occurs, the screen turns on, the fault icon flashes and a fault message is displayed. The screen will cycle every 4 seconds between 2 displays, one giving the fault message and one giving the amount of time in the lockout state. For example, if the cause was loss of the CO input the fault icon would flash and the message would read "CO detected." After 4 seconds, the time in the lockout state "secs or mins" will be displayed. This cycle will continue until the fault is resolved.
	Primary control is in Latch-up	When Latch-up occurs, the fault icon will flash and the screen will show "Latch-up" along with time spent in Latch-Up state. See page 15 for the procedure to handle this condition. When resetting the 60200FR control from Latch-up, be sure to investigate what caused the repeated failures. Correct the condition.
	Incorrect wiring	Check wiring against appliance and burner wiring diagrams. Verify all connections are secure.
	Defective motor	Remove motor leads from the burner junction box and apply power directly. If motor fails to operate, then replace.
	Defective primary control	If control receives power to both the black and red/white wires, but doesn't start the motor, the control may be defective. Replace control.
	Flange door switch	Make sure flange door is closed securely and that door switch is closed.
	Gas pressure	Check low gas pressure switch. If it is open, gas supply may be too low or no gas flow — check supply line and manual valves. Gas train inlet pressure should be at least 5" w.c. when burner is operating. Check high gas pressure switch. It should be closed. If it is open, gas pressure to manifold may be too high.
Repeated flame failures — burner won't light	Airflow problem	Check air band setting against Table 1, page 7. Reposition to correct setting if necessary. Check blower wheel to verify it is turning.
	Gas orifice	Check gas orifice size. See Table 1, page 7.
	Manifold pressure	Check gas manifold pressure — should be between 3.2 and 3.8 inches w.c. unless specified.
	Ignition — no spark or poor spark	Check wire connections to ignitor electrode at primary control and electrode end. Check position of ignitor electrode per page 8. Adjust if needed. Check voltage to ignitor. If ignitor receives 120 VAC and doesn't generate spark, replace ignitor.
	Gas valves not opening	Check gas supply pressure to gas train. Pressure in excess of 14 inches w.c. will cause valves to lockup. Check voltage to gas valves. Are gas valves receiving 120 VAC? If gas valves are receiving 120 VAC and not opening, and gas supply pressure is below 14 inches w.c., replace gas valve(s).
	Airflow switch	Check electrical connections and sensing connections to airflow switch. If blower operates, check across switch to see if it makes. If switch is correctly connected, but won't close, replace airflow switch. To verify switch is receiving signal, connect a manometer across the sensing lines.
	Primary control defective	Check voltage to gas valves during TFI. If no voltage to valves, replace the primary control.

## 7. Troubleshooting (continued)

Problem	Possible cause	Corrective action
<b>WARNING</b>		These procedures must only be performed by a qualified service technician. Use care when performing tests on electrically or mechanically live parts. Disconnect power to burner/appliance and close main manual gas valve when removing components for service. Failure to comply could result in severe personal injury, death or substantial property damage.
Burner lights, but locks out after TFI	Insufficient flame signal	60200FR must display at least 0.8 microamps. Check following if signal is lower. Flame rod may be touching ground, insulator may be broken, or contamination may cause path to ground. Inspect and clean if necessary. See Figures 5 and 6, page 8 for more information. Check flame rod position in burner per Figures 5 and 6, page 8. Adjust if necessary. Flame rod must be correctly positioned for best flame signal.
	Ignition — no spark or poor spark	Check wire connections to ignitor electrode. Check position of ignitor electrode per Figures 5 and 6, page 8. Adjust if needed. Check primary voltage to ignitor. If ignitor receives 120 VAC and doesn't generate spark, replace ignitor.
	Airflow	Check air band setting against Table 1, page 7.
	Wrong orifice size	Verify orifice size per Table 1, page 8. See pages 7 and 8 for procedure.
	Manifold pressure	Check combination gas valve outlet pressure — should be between 3.2 and 3.8 inches w.c., unless specified.
	Inadequate gas supply	Check line pressure at combination gas valve supply pressure tapping. Gas pressure must be at least 5 inches w.c. If other appliances are on same line or regulator and burner pressure drops when they are on, line is undersized. Contact your gas supplier. If gas pressure is always low, check supply regulator setting and adjust if necessary. Gas pressure must not exceed 14 inches w.c.
	Improper draft	Over-fire draft should not be higher than specified in the appliance manufacturer's instructions. Follow the appliance manual instructions to troubleshoot excess overfire pressure or poor draft problems if necessary.
	Flame rod grounded	Check flame rod and insulator. If flame rod is grounded in any way, the control will lockout after the trial for ignition.
	120 VAC polarity	Check polarity of power supply. If hot and neutral wires are reversed, flame rod circuit cannot sense flame correctly. Control will lockout after the trial for ignition.
Flame rod wire	Check to make sure the connections are tight at the electrode and at the terminal on the 60200FR control.	

Where appliance instructions differ from this manual, follow the appliance instructions.

## 8. Dimension and Mounting Information

**Figure 13** Dimensional data

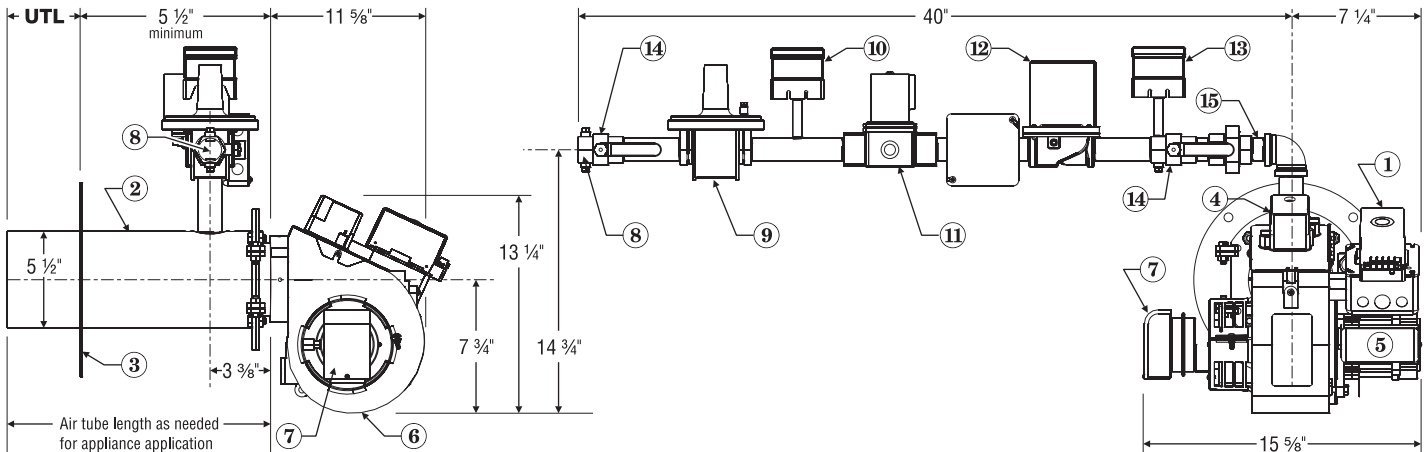

- |                         |                            |                             |
|-------------------------|----------------------------|-----------------------------|
| 1 Carlin 60200 primary  | 6 Cast aluminum housing    | 11 Secondary gas valve      |
| 2 Air tube              | 7 Air flow switch          | 12 Primary gas valve        |
| 3 Flange (welded shown) | 8 Gas connection, 1" NPT   | 13 High gas pressure switch |
| 4 Carlin 41800 ignitor  | 9 Gas pressure regulator   | 14 Manual gas cocks         |
| 5 Carlin PSC motor      | 10 Low gas pressure switch | 15 Orifice nipple           |

### Mounting burner to appliance

**WARNING**

Positive overfire pressure applications: When firing with positive overfire pressure, do not exceed the pressure specified in the appliance manual.

Positive overfire pressure reduces maximum burner capacity. See Table 1 notes for estimated reduction in burner capacity with pressurized firing.

When using the adjustable flange, follow the steps in Figure 14 to prepare for pressurized firing.

Failure to comply could result in severe personal injury, death or substantial property damage.

When using a welded flange burner, verify the insertion depth on the appliance and burner (see page 7).

If using the adjustable flange (Figure 14), measure the appliance insertion depth to set the position of the flange on the air tube. Tighten the flange locking screws firmly. Prepare the appliance opening to the dimensions shown in Figure 14. Also read page 7.

**Figure 14** Adjustable flange mounting information

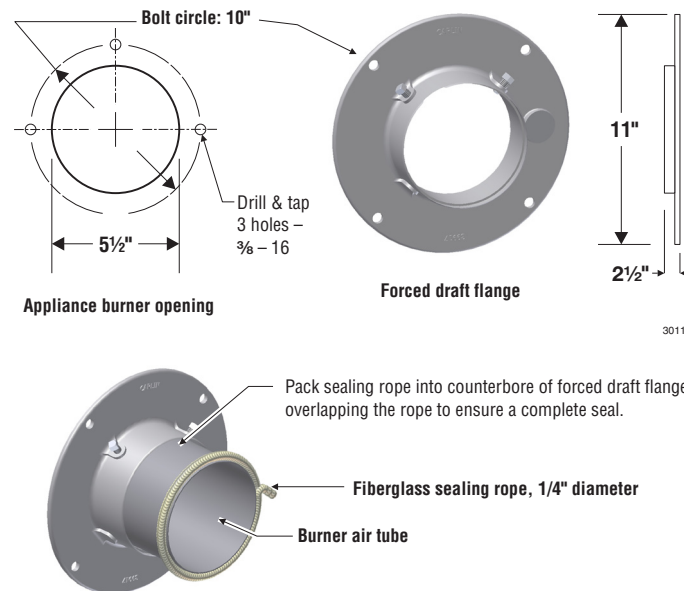

## 9. Replacement Parts – Burner

ITEM	PART NO.	DESCRIPTION
1	99259S	301/601Gas Airtube 14" B , 1" inlet for rates 401,000 to 700,000 BTU's.
	99189S	301/601Gas Airtube 14" C , 1" inlet for rates 550,000 to 1,100,000 BTU's.
2	99225KITS	Flange/Gasket kit for 301GAS/601GAS
3	99164S	Combustion Head Assembly "B" Head
	99277S	Combustion Head Assembly "C" Head
4	99254S	Airband/Air Shutter Kit
5	28563S	Blower wheel/ fan
6	98611S	Motor 1/6HP, 120V, 60HZ , 48N Frame
7	99158S	Ignition Electrode/Flame Rod 301GAS
8	98521KITS	Airflow switch and mounting plate assembly for 201/301/601GAS
9	60200FR343S	Primary Control Microprocessor Flame Rod
10	99260S	Gasket Kit (Includes 40253, 99260, 99430)
11	99162S	Retention Ring Assy
12	30GFRWIRES	Flame Rod Wire 24" for 301/601Gas (not shown)
13	99261KITS	Door Interlock Switch and Mounting Screws
14	4180002S	Ignitor for 301GAS
15	99153KITS	Electrode/Flame Rod Bracket assembly

*See Gas Train Wiring Supplement for parts breakdown and diagrams for all gas trains.*

Where appliance instructions differ from this manual, follow the appliance instructions.

## 9. Replacement Parts – Burner (continued)

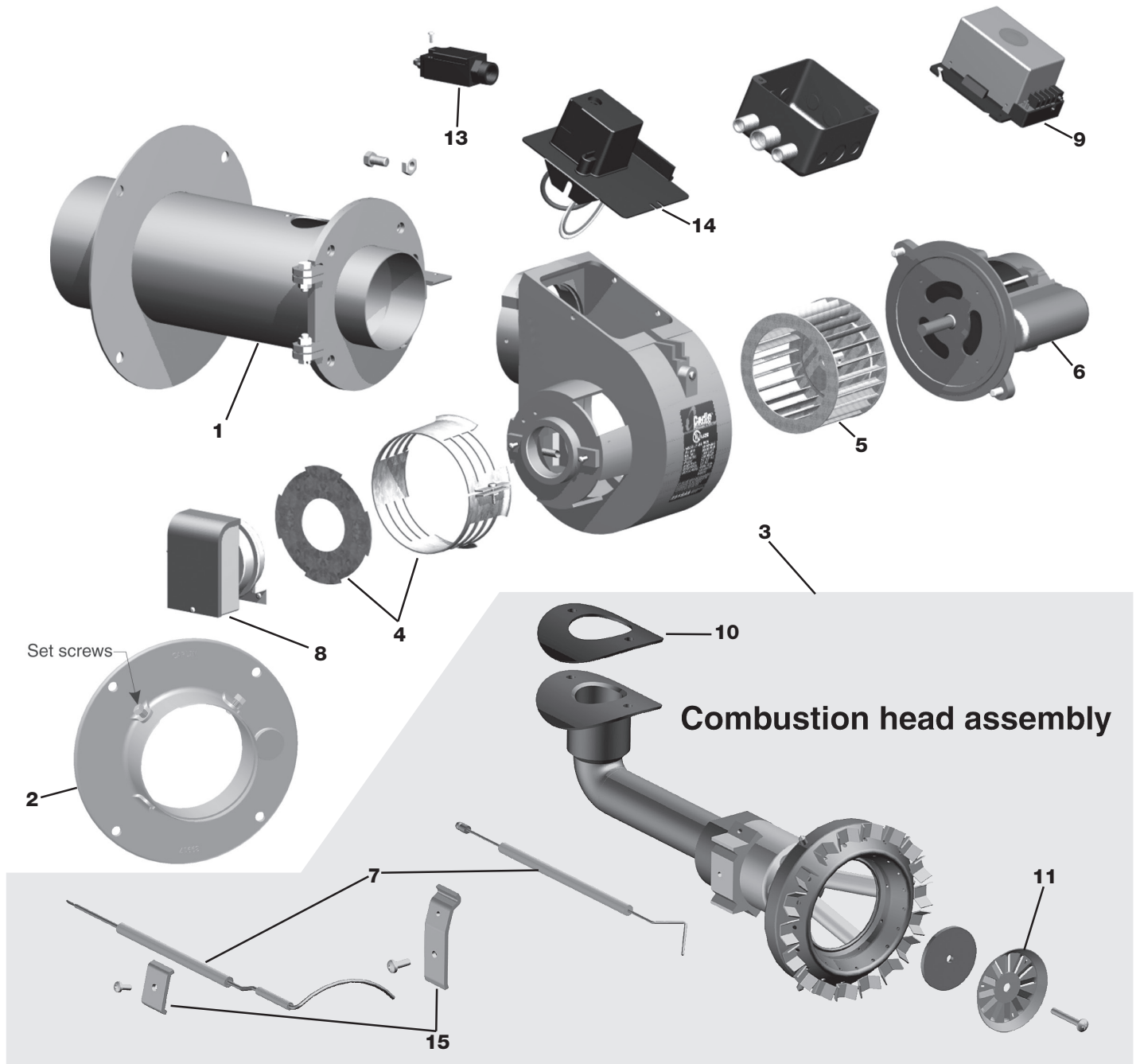

**NOTICE**

Burner is shown with welded flange, supplied only on burners ordered for specific appliance applications. Other burners are supplied with the optional forced draft adjustable flange (item 18). See page 19 for details.

**Installation/service certificate**

**Installation data**

Burner model	Serial number	Measured firing rate, Btuh	Gas orifice drill size	Manifold gas pressure, IWC	Inlet gas pressure, IWC
O2%	CO2%	CO, PPM	Flame Signal	Fuel (natural or propane)	Were controls tested?

Comments about installation/start-up:

Installer's name:	Company name:	Company address:	Phone:
-------------------	---------------	------------------	--------

**Service history**

Date	Technician	Company/address	Describe work performed