

**6.0 to 11.2 GPH Oil**  
**840 to 1600 MBH Gas**  
(High-fire input capacities)

## Instruction Manual

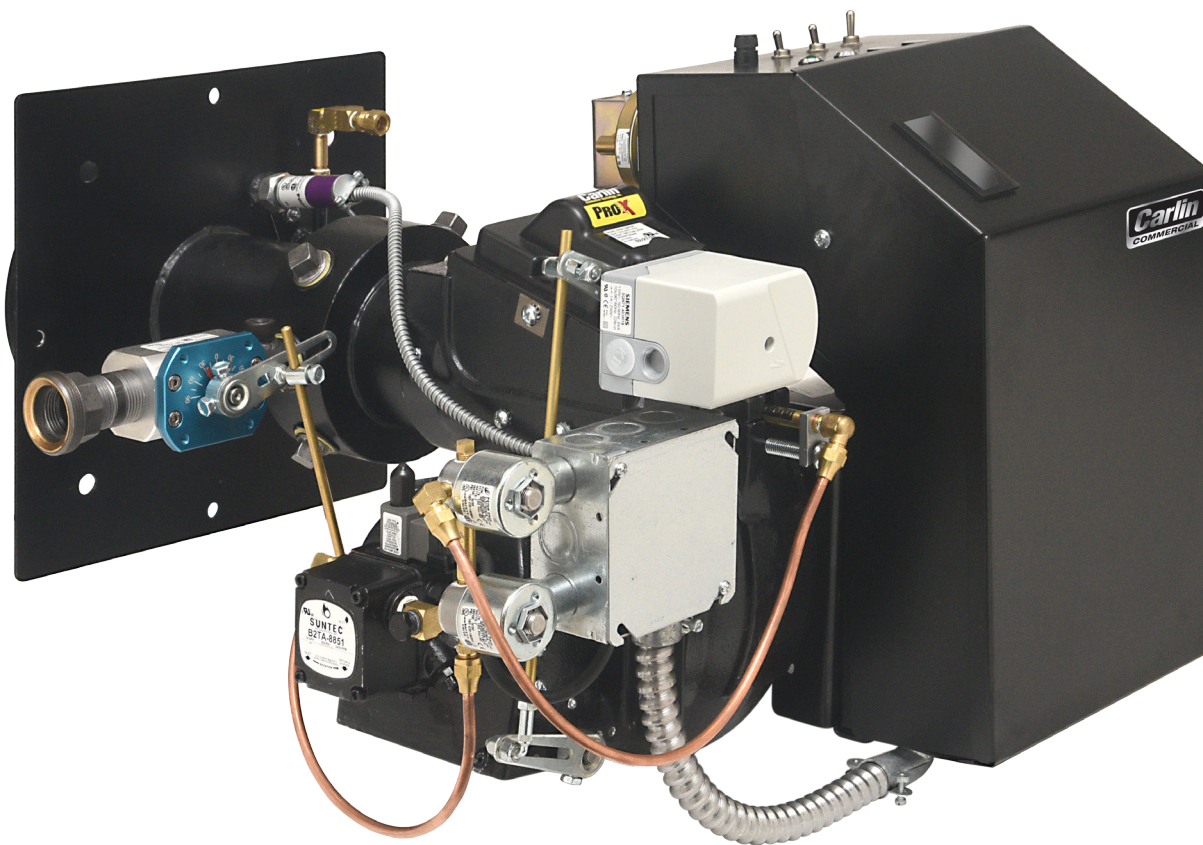

**WARNING**

Except where specifically stated otherwise, this manual must be used only by a qualified service technician.

In the state of Massachusetts, this product must be installed by a licensed Plumber or Gas Fitter.

Failure to comply with the above or other requirements in this manual could result in severe personal injury, death or substantial property damage.

**WARNING**

**USER** — Refer only to User care and maintenance on back page for information regarding operation of this burner. The burner Instruction Manual is intended only for your service technician. The burner and heat exchanger must be inspected and started at least annually by your service technician.

**NOTICE**

Check burner cartons carefully. The Model 702G/O combination gas/oil burner was assembled and tested at the factory before shipment. If the burner was ordered with a completed assembled gas train, the train was pressure tested and electrically checked for proper operation. Where possible, the gas train or components were shipped in the same carton as the burner. Check your packing slip for the number of cartons shipped from the factory.

© Copyright 2020 — Carlin Combustion Technology

**Carlin Combustion Technology**  
126 Bailey Road  
Ph 203-680-9401  
North Haven, CT 06473  
Fx 203-680-9403

# PLEASE read this first . . .

## Contents

PLEASE read this first .....2

General information .....3

1. The Carlin Model 702G/O combination gas/oil burner .....4

2. Pre-fire Inspection/Preparation.....5

3. Install gas piping.....12

4. Install oil piping.....14

5. Wire the burner.....16

6. Checkout procedure — before starting the burner .....18

7. Set burner initial head and damper positions .....18

8. Adjust the burner using test instruments .....20

9. Maintenance and service procedures .....25

10. Repair parts .....28

11. Dimensions .....31

User care and maintenance ..... Rear cover

## Special attention flags . . .

Please pay particular attention to the following when you see them throughout this manual.

**DANGER** Notifies you of hazards that WILL cause severe personal injury, death or substantial property damage.

**WARNING** Notifies you of hazards that CAN cause severe personal injury, death or substantial property damage.

**CAUTION** Notifies you of hazards that WILL or CAN cause minor personal injury or property damage.

**NOTICE** Notifies you of special instructions on installation, operation or maintenance that are important, but are not normally related to injury or property damage hazards.

## Before installing or servicing:

- WARNING** (1) Shut off the oil and gas supplies to the burner.  
 (2) DO NOT shut off the control switch to the boiler circulator or the burner.

**WARNING** Follow the guidelines below to avoid potential severe personal injury, death or substantial property damage.

## Installer/service technician . . .

- Read all instructions before proceeding. Perform all procedures, and in the order given to avoid potential of severe personal injury, death or substantial property damage.
- Before leaving the site after startup or service, review the User care and maintenance page with the user. Make the user aware of all potential hazards and perform the training outlined below.

## Installer/service technician — Train the user . . .

- To properly operate the burner/appliance per this manual and the appliance instructions. See User care and maintenance.
- To keep this manual at or near the burner/appliance for ready access by the user and service technician.
- To keep the appliance space free of flammable liquids or vapors and other combustible materials.
- To never use laundry products, paints, varnishes or other chemicals in the room occupied by the burner/appliance.
- To contact the service technician at least annually for startup and burner/appliance service.

## When servicing the burner . . .

- DISCONNECT ELECTRICAL SUPPLY and all other electrical connections to burner before attempting to service to avoid electrical shock or possible injury from moving parts.
- CLOSE all manual gas and oil valves before disconnecting any portion of fuel lines and before cleaning or removing any parts from the burner or related equipment.
- Burner and appliance components can be extremely hot. Allow all parts to cool before attempting to handle or service to avoid potential of severe burns.

Where appliance instructions differ from this manual, follow the appliance instructions.

## General information

### Burner applications

Follow all instructions in this manual, the primary control data sheet and the appliance manual.

Adjust the nozzle selection/firing rate if necessary due to positive overfire pressure and/or altitudes more than 2,000 feet above sea level. See the NOTICE under the Ratings information at right. Where appliance application information is available, the recommended firing rate and burner information will include appropriate adjustments for positive overfire pressure and recommendations for high altitudes. Follow the appliance manual guidelines when available.

### Damage or shortage claims

The consignee of the shipment must file damage or shortage claims immediately against the transportation company. See the NOTICE on page 1 for burner carton information.

### When calling or writing about the burner:

Please provide us with the UL serial number and burner model number to assist us in locating information. This information can be helpful when troubleshooting or obtaining replacement parts.

### Codes and standards

#### Certification

702G/O burners are U.L. listed for the U.S., certified to comply with:

- ANSI/UL 296, for use with #1 or #2 heating oil (per standard ASTM D396).
- UL 795, for use with natural gas or propane.
- CUL certified CSA B140.2.1.10, CGA3.4-1973
- Burner labels list compliance, when required, with special local, state or provincial approvals.
- 702G/O burners can be configured for local code compliance.

#### United States installations

Burner/appliance installations in the United States must comply with the latest editions of:

- Installation of Domestic Gas Conversion Burners, ANSI Z21.8.
- National Fuel Gas Code, ANSI Z223.1/NFPA 54.
- Standard for the Installation of Oil-Burning Equipment, NFPA 31
- National Electrical Code, ANSI/NFPA 70.
- All additional applicable national, state and local codes. Regulations of these authorities take precedence over the general instructions provided in this manual.

### Ratings

Altitude 2,000 feet max. (see NOTICE below)

#### Oil Input

..... High fire: 6.0 to 11.2 GPH  
 ..... Low fire: 3.5 to 6.5 GPH

#### Gas Input

..... High fire: 840 to 1,600 MBH  
 ..... Low fire: 490 to 940 MBH

#### Fuels

..... No. 1 or No. 2 Fuel oil  
 ..... Natural gas or propane

#### Fuel Unit & Oil Valves

... Fuel unit, 2-stage, 300 psig (with internal blocking valve)  
 ..... (2) Oil solenoid valves

#### Gas Train (available in straight or angled configuration)

..... (2) Main gas valves & RV-61 or RV-81 regulator  
 ..... Butterfly gas valve for input regulation  
 ... 1" gas train standard; 1¼", 1½" or 2" gas train available

#### Electrical

Power ..... 120V/60 Hz/1-Phase  
 Limit circuit input (RM7895C or RM7897C) .... 120 vac/60 hz  
 Control circuit load (120 vac)..... 1.2 amps  
 Motor ..... 1/2 hp, 3450 rpm, 48-frame, "N" flange  
 ..... 115 / 208-230 vac/60 hz/1-ph, 8.4 / 3.8-4.2 amps  
 Oil valve/gas valve power ..... 120 vac/60 hz  
 Damper motor ..... Siemens SQN71

#### Ignition & Primary Control

Oil ..... Carlin Model 45000 electronic ignitor, 14,000 volts  
 Gas ..... Carlin Model 41800 electronic ignitor, 9,000 volts  
 Primary ..... Honeywell RM7897C  
 Alternate ..... Fireye MEC120

#### Agencies

..... UL Listed (US)

#### NOTICE

Reduce nozzle/firing rate when required – Maximum burner capacity is reduced when overfire pressure is positive and for altitudes above 2,000 feet. See below, and adjust firing rate/nozzle selection if necessary.

| 702G/O — Maximum firing rate for positive overfire pressure and high altitude |           |           |
|---|-----------|-----------|
| Overfire pressure (Inches w.c.)   | Oil – GPH | Gas – MBH |
| 0.00  | 11.2      | 1,600     |
| 0.10  | 10.9      | 1,530     |
| 0.20  | 10.7      | 1,500     |
| 0.30  | 10.6      | 1,480     |
| 0.40  | 10.3      | 1,440     |
| 0.50  | 10.2      | 1,430     |
| 0.60  | 9.9       | 1,390     |

**Altitudes:** For altitudes more than 2,000 feet above sea level, reduce the above capacities an additional 4% per 1,000 feet higher than 2,000 feet above sea level.

# 1. The Carlin Model 702G/O combination gas/oil burner

## 702G/O overview

The Model 702G/O combination gas/oil burner is a low-high-low (step modulating) burner that utilizes a damper motor to control air (and gas fuel rate). Fuel is selected using the Gas/oil changeover switch. The burner operates on either #2 fuel oil or gas (natural or propane).

See the next page for gas train component locations.

## Gas mode operation

Ignition for main flame is accomplished by a proved gas pilot of approximately 70,000 Btuh. Pilot gas is introduced and ignited by a Carlin 9,000-volt electronic ignitor wired to the electrode. After the pilot flame is proven, the two main gas safety valves open. The pilot gas valve closes after a time delay to allow main flame to establish. Flame is monitored both for pilot flame and main flame with a UV scanner positioned in the mounting flange. The burner main flame begins at low fire. If additional input is required, the damper motor opens the gas butterfly valve and air damper to their high fire positions.

Gas is introduced into the burner through a manifold around the air tube. The gas then circulates through a set of four orifice spuds into the air stream, upstream of the retention ring. The spin of the air flow at the retention ring thoroughly mixes the gas/air before it reaches the combustion zone.

## Oil mode operation

Oil ignition is accomplished by the Carlin 14,000-volt electronic ignitor wired to the two electrodes. The oil flame begins at low fire, with 100 PSIG oil pressure at the nozzle. If additional input is needed, the damper motor opens the air to the high fire position (reference Supplement MNSQN71 for detailed instructions on operating the damper motor). The transition cam (orange) energizes the 2nd stage oil valve (fuel unit blocking valve) as the damper approaches its high fire position. This provides 300 PSIG pressure to the oil nozzle for high fire. Flame is monitored by the UV scanner mounted to the under side of the combustion head assembly.

## Firing rate adjustment

- Firing rate is determined by the oil nozzle. Air flow is matched to the oil flow for oil firing. Then gas flow is adjusted to match the air flow at low and high fire rates. NOTE: High Fire must be set before Low Fire.
- See the “Starting and operating” section on page 12 of this manual for the complete description of the adjustment process. The following is a brief summary only.
- High-fire air is set by adjusting the combustion head position (to control air flow through and around the retention ring).
- Low-fire air is then adjusted by altering the position of the low fire adjusting screw.

## 702G/O oil nozzles

**NOTICE** Use the selections below when the heating equipment manufacturer’s specific nozzle selection data is not available, either in the equipment manual or the Carlin OEM Spec Guide. Follow all instructions provided with the appliance.

## Nozzle specifications

- Preferred — Hago 45° B
- Alternate — Delevan 45° B or Monarch 45° PLP

## Nozzle ratings

Full input (high fire) occurs at 300 psig nozzle pressure. Since nozzles are rated at 100 psig, the actual flow at 300 psig is approximately 73% higher than the rated nozzle capacity. See the table below for nozzle rating selections.

Table 1 702G/O oil nozzles

| Oil Nozzle Sizing          |                               |                           |                            |
|----------------------------|-------------------------------|---------------------------|----------------------------|
| Equipment Input rating GPH | Recommended nozzle rating GPH | Low fire input (100 psig) | High fire input (300 psig) |
| 6.00                       | 3.50                          | 3.50                      | 6.00                       |
| 6.50                       | 3.75                          | 3.75                      | 6.50                       |
| 6.90                       | 4.00                          | 4.00                      | 6.90                       |
| 7.80                       | 4.50                          | 4.50                      | 7.80                       |
| 8.70                       | 5.00                          | 5.00                      | 8.70                       |
| 9.50                       | 5.50                          | 5.50                      | 9.50                       |
| 10.40                      | 6.00                          | 6.00                      | 10.40                      |
| 11.20                      | 6.50                          | 6.50                      | 11.20                      |

1. For a packaged appliance application on which the burner has been tested, use the nozzle given in the appliance manufacturer’s instructions or supplement for the best results.

## Gas pressure requirements

Standard gas train requirements for the 702G/O burner requires a minimum w.c. inlet of 5" under flow conditions (maximum 14"). Systems with high pressure (above 14" w.c.) require a line pressure regulator upstream.

Where appliance instructions differ from this manual, follow the appliance instructions.

## 2. Pre-fire inspection • preparation

### Vent system

#### Vent/chimney sizing

1. Follow all local codes when sizing the vent and chimney.
2. Refer to the appliance manufacturer's manual, when available, for venting recommendations.

### Combustion air/ventilation openings

#### Combustion air/ventilation opening checklist

- Verify that air openings are unobstructed.
- Verify that appliance space and air source spaces are free of:
  - Gasoline or other flammable liquids or vapors.
  - Combustible materials.
  - Air contaminants, such as laundry products, paint, thinner, varnish, etc.
- Confirm with user that the area will be kept free of these materials at all times.
- All air from inside building (building must be well-ventilated):  
Size air openings for a free area (after louver deduction) of at least 1 square inch per 1,000 Btuh input of all appliances in the space.
- All air through openings directly from outside the building through an adjacent outside wall:  
If air openings connect directly to outside, provide two openings, one within 12 inches of the ceiling, the other within 12 inches of the floor. Each opening must have a free area (after louver deduction) of:
  - If directly through side wall: 1 square inch for each 4,000 Btuh of all appliances in the space.
  - If through vertical ducts: 1 square inch for each 4,000 Btuh of all appliances in the space.
  - If through horizontal ducts: 1 square inch for each 2,000 Btuh of all appliances in the space.

#### WARNING

Do not install or operate the burner if any component is damaged or if burner does not comply with other guidelines of this manual and the appliance manual.

#### Inspect, repair and/or replace vent system

#### WARNING

Do not install this burner unless you have verified the entire vent system and the appliance are in good condition and comply with all applicable codes. And . . .

The vent and chimney must be sized and constructed in accordance with all applicable codes. If intended for use with an oil burner as well, the vent system must comply with relevant codes for both gas and oil firing.

The vent system must not be pressurized unless the vent piping and vent system are designed accordingly. The vent must provide draft at all times (negative pressure in vent).

Do not install or use an existing manual damper in the vent connector or vent.

Do not connect the appliance vent connector to a chimney or vent serving a fireplace, incinerator or solid-fuel-burning apparatus.

In a cold climate, do not vent into a masonry chimney that has one or more sides exposed to the outside. Install a listed stainless steel liner to vent the flue products.

A defective vent system could result in severe personal injury, death or substantial property damage.

## 2. Pre-fire inspection • preparation (continued)

### Prepare vent/chimney

1. Secure all metal vent joints with screws, following the vent manufacturer's instructions. Seal all joints in the vent system and chimney. Repair masonry chimney lining and repair all mortar joints as needed.
2. Where draft fluctuations are likely, install a double-acting barometric draft regulator in the vent piping. (The damper must be located in the same space as the appliance.) Install a manual reset spill switch in the top of the draft regulator outlet. Wire the switch into the appliance limit circuit to shut off the appliance/burner if sustained downdraft should occur. Refer to the appliance manufacturer's instruction manual for recommendations regarding the need for a barometric draft regulator.
3. Provide support for the vent piping. Do not rest the weight of any of the vent piping on the appliance flue outlet.

### Clearances

#### Check codes, standards and the equipment manual

- Verify that the burner/appliance will maintain all clearances to combustible walls or floor and all clearances required for service/maintenance as required in the appliance manual and applicable codes.

Figure 1 Vent and vent connector installations, typical

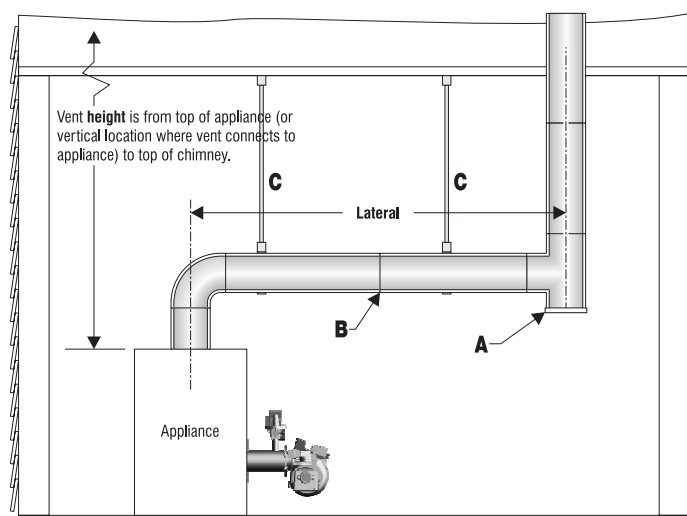

#### Metal vent application

- A** Connect to vertical with tee, if possible, to provide inspection/cleanout opening in vent.
- B** Seal all joints and access openings tightly to prevent draft loss.
- C** Support vent pipe so no weight of vent connector rests on appliance.

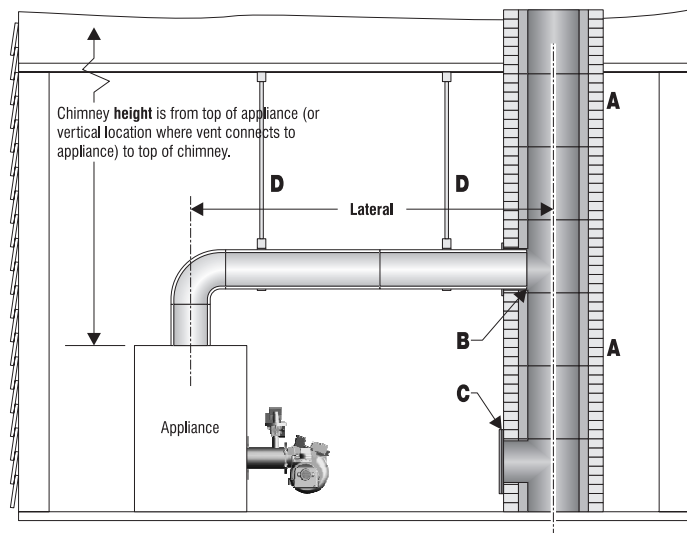

#### Masonry chimney application

- A** Tile-lined interior masonry chimney only; with all tile and joints in good condition.
- B** Vent pipe should be almost flush, but *not extending into*, inside surface of liner.
- C** Seal all access openings tightly to prevent draft loss.
- D** Support vent pipe so no weight of vent connector rests on appliance.

60102

Where appliance instructions differ from this manual, follow the appliance instructions.

## 2. Pre-fire inspection • preparation (continued)

### Prepare the appliance

**WARNING** Burner input: Install a burner sized for the normal input rating of the appliance. Do not install a burner with a higher firing rate than the appliance rating. Do not install a burner with a firing rate more than 10% lower than the appliance rating. The appliance and vent system could be damaged due to condensation.

**Clean the appliance:** Clean the appliance thoroughly. Test all electrical components and verify the relief valve works (boilers only).

**Seal the appliance:** Seal all flue-gas containing joints. Seal all connections to the vent piping or breeching.

Verify combustion chamber dimensions comply with the minimum dimensions recommended on page 9. Install or replace chamber liner if required by the appliance manufacturer. The burner must not extend into the combustion chamber. The end of the burner air tube must be within 1/4" of the inside face of the chamber. If the space around the burner air tube is more than 1/4", wrap the burner air tube with minimum 2300-°F-rated ceramic fiber blanket to seal off the gap.

Repair or replace damaged appliance components. Inspect the appliance thoroughly. Follow appliance manufacturer's guidelines for repair or replacement of any component found defective.

When cleaning the appliance or working with ceramic fiber refractories or fiberglass insulation, see WARNING on this page.

Failure to comply with the above could result in severe personal injury, death or substantial property damage.

### Prepare appliance for burner mounting

**WARNING** Positive overfire pressure applications: When firing with positive overfire pressure, do not exceed the pressure specified in the appliance manual.

Positive overfire pressure reduces maximum burner capacity. See Page 3 for estimated reduction in burner capacity with pressurized firing and high altitude applications.

Failure to comply could result in severe personal injury, death or substantial property damage.

### Ceramic fiber or Fiberglass insulation

**WARNING** Ceramic fiber materials, such as chamber liners, may contain carcinogenic particles (chrysothalites) after exposure to heat. Airborne particles from fiberglass or ceramic fiber components have been listed as potentially carcinogenic by the State of California. Take the following precautions when removing, replacing and handling these items.

**Avoid breathing dust and avoid contact with skin or eyes.** Wear long-sleeved, loose-fitting clothing, gloves and eye protection. Use a NIOSH N95 certified respirator. This respirator meets requirements for protection from chrysothalites. Actual job requirements or NIOSH regulations may require other or additional protection. For information, refer to the NIOSH website, <http://www.cdc.gov/niosh/homepage.html>.

**Ceramic fiber removal:** To prevent airborne dust, thoroughly wet ceramic fiber with water before handling. Place ceramic fiber materials in a plastic bag and seal to dispose.

**Avoid blowing, tearing, sawing or spraying** fiberglass or ceramic fiber materials. If such operations are necessary, wear extra protection to prevent breathing dust.

**Wash work clothes separately from other laundry.** Rinse clothes washer thoroughly afterwards to prevent contamination of other clothing.

#### NIOSH First aid procedures:

Eye exposure — irrigate immediately

Breathing — fresh air.

## 2. Pre-fire inspection • preparation (continued)

### Prepare burner and components

**WARNING** Do not install or operate the burner if any component is damaged or if burner does not comply with the specifications of Table 2 and other guidelines in this manual.

### Combustion chamber minimum dimensions

- For applications that have not been specifically tested (OEM applications), verify that the combustion chamber provides the minimum dimensions shown in Table 2 and Figure 2. For specific OEM applications, the appliance testing ensures suitability of the chamber.
- Chamber dimensions may be larger than listed in Table 2, but should not be excessively large.

**WARNING** Combustion chambers should be sized as recommended in Table 2. They should be constructed of refractory materials with the capacity to withstand 2600°F or higher.

It is difficult to include all possible chamber constructions in this manual. Therefore, you should use the information presented in this manual combined with commonly practiced techniques when determining chamber design. If certain conditions are in question, consult the factory.

### Using chamber linings

- When using refractory liners or lightweight chambers, use insulating-type refractory rated 2600°F minimum, or as specified by the appliance manufacturer.
- You must install a target wall liner if flame length is close to the length of the chamber.
- Use a floor liner when possible. The floor liner will improve firing in most applications. Extend floor liner 3 to 4 inches up the side walls.
- Target wall liners — Extend target wall liners at least 3 to 4 inches above the center of the flame corbel the top 1½ to 2½ inches deep.
- Use preformed chamber liners when available. Lining the floor and target wall water-backed combustion chambers with lightweight insulating refractory will accomplish the same.
- When converting coal-fired units, install a combustion chamber in the ashpit area, or fill the ashpit with sand up to 2 inches above the “mud ring” of the boiler (firing through the door). Install a lightweight refractory liner on the target wall.

### Air tube insertion length (UTL)

- Usable air tube length (UTL) is the distance from mounting flange to end of air tube. Verify that the end of the air tube will be flush with, or no more than 1/4 inch short of, the inside of the appliance combustion chamber front wall when the burner is mounted. See Figure 2 for further information.

NOTE: A space is available for an appliance with a UTL less than 4" (consult factory).

Figure 2 Chamber dimensions & tube configurations

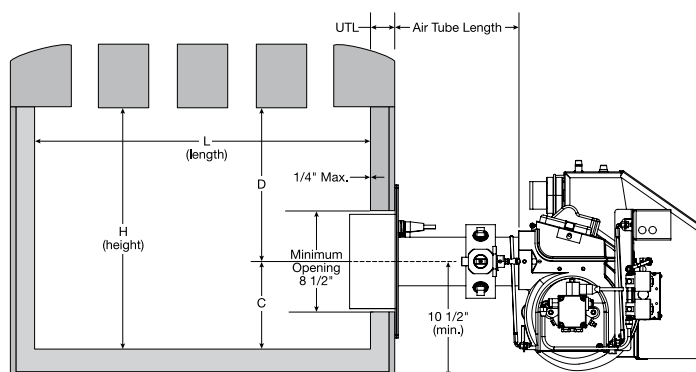

Table 2 Minimum combustion chamber dimensions (see Figure 3)

| High fire input |         | Refractory combustion chamber applications<br>(all dimensions in inches) |      |      |     |
|-----------------|---------|--|------|------|-----|
| Oil-GPH         | Gas-MBH | “L”  | “W”  | “C”  | “H” |
| 6.00            | 840     | 21   | 15.0 | 7.5  | 15  |
| 6.50            | 910     | 23   | 15.5 | 8.0  | 16  |
| 6.90            | 966     | 25   | 16.0 | 8.0  | 16  |
| 7.80            | 1092    | 28   | 17.0 | 8.5  | 17  |
| 8.70            | 1218    | 31   | 17.5 | 9.0  | 18  |
| 9.50            | 1330    | 34   | 18.0 | 9.0  | 18  |
| 10.40           | 1456    | 38   | 19.0 | 9.5  | 19  |
| 11.20           | 1568    | 43   | 20.0 | 10.0 | 20  |

| High fire input |         | Refractory combustion chamber applications<br>(all dimensions in inches) |                  |      |      |      |
|-----------------|---------|--|------------------|------|------|------|
| Oil-GPH         | Gas-MBH | “L”<br>W/target  | “L”<br>No target | “W”  | “C”  | “D”  |
| 6.00            | 840     | 21   | 25               | 17.0 | 8.5  | 10.5 |
| 6.50            | 910     | 23   | 27               | 17.5 | 9.0  | 11.0 |
| 6.90            | 966     | 25   | 29               | 18.0 | 9.0  | 11.0 |
| 7.80            | 1092    | 28   | 32               | 19.0 | 9.5  | 11.5 |
| 8.70            | 1218    | 31   | 35               | 19.5 | 10.0 | 12.0 |
| 9.50            | 1330    | 34   | 38               | 20.0 | 10.0 | 12.0 |
| 10.40           | 1456    | 38   | 42               | 21.0 | 10.5 | 12.5 |
| 11.20           | 1568    | 43   | 47               | 22.0 | 11.0 | 13.0 |



Where appliance instructions differ from this manual, follow the appliance instructions.

## 2. Pre-fire inspection • preparation (continued)

### Install the burner pedestal

**NOTICE** 702G/O burners are also supplied with a pedestal for supporting the burner. (The pedestal is available as an option for a burner equipped with a welded flange.)

1. Adjust the pedestal so that the height of the air tube matches the location of the burner opening.
2. The pedestal has approximately 3" of adjustment. If the burner opening is too high for the pedestal to rest on the floor, then construct a base. Two solid cement blocks, side by side, is recommended. Alternate the direction as layers are put down.
3. Place a spirit level on the air tube. Adjust the pedestal so the air tube slopes down slightly toward the appliance. The slope should be about 2 degrees.
4. Tighten the pedestal bolt securely.

### Install the oil nozzle

1. Follow the instructions on page 10 to remove the combustion head assembly.
2. Install and tighten the nozzle listed in the appliance instruction manual or the Carlin OEM Spec Guide. If nozzle information is not available, begin with the nozzle listed on page 4. (You may have to change the nozzle later if combustion results are not acceptable.)
3. Hold the nozzle adapter securely when removing or replacing the nozzle. Take care not to damage the electrode insulators or to bend the electrodes in the process.

**WARNING** Inspect the nozzle adapter before replacing the nozzle. If the threads have been damaged or show score marks, replace the nozzle line/adapter assembly.

## 2. Pre-fire inspection • preparation (continued)

### Removing the combustion head assembly

1. To check the electrode settings or change the nozzle, you must remove the combustion head assembly from the air tube. Follow the steps below, and reverse the sequence to reassemble.
2. Shut off the burner.
3. Remove the four gas orifice spuds from the manifold (Figure 3A).
4. Disconnect the 1/4" O.D. copper oil line.
5. Remove the two housing cover locking screws and swing the housing open.
6. Partially remove the combustion head assembly, and disconnect the two ignition cables from the electrodes and thermal fuse wires.

### Setting the electrodes

1. Check the electrodes and reposition if necessary. Position the electrodes as shown in Figure 3. These settings are critical in ensuring a reliable ignition.
2. Once the electrodes are set, check all clamps to be sure they are securely tightened.
3. Insert the combustion head/nozzle assembly into the burner and secure in place (see instructions above).

**Figure 3** Electrode settings

Electrodes should form a slight "V" as shown with spacing as shown between closest points.

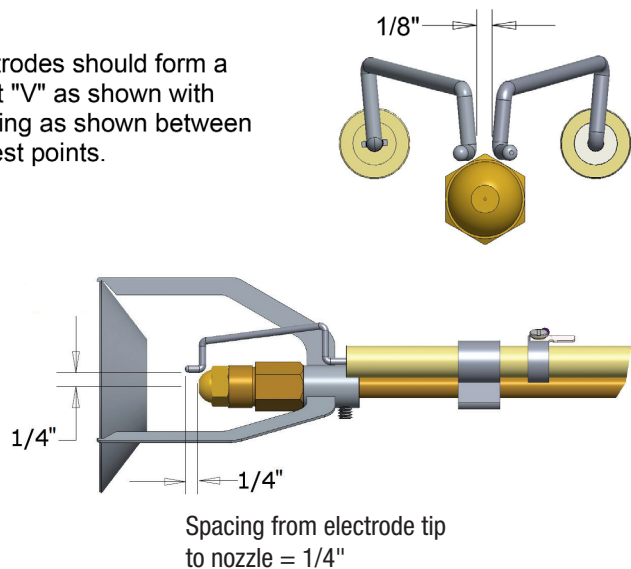

**WARNING**

Installing the burner/appliance in a space that does not provide enough air for combustion and ventilation can result in severe personal injury, death or substantial property damage. Follow all applicable codes and guidelines below to ensure space has sufficient air openings.

**WARNING**

Exhaust fans and negative pressure conditions — Isolate the boiler room from areas subject to negative pressure. Size combustion air openings to ensure neutral air pressure in the boiler room whenever the burner operates.

**WARNING**

Make sure the space provides enough ventilation to prevent overheating of the appliance, burner and controls. If there is risk of overheating, you must install ventilation air openings sized large enough to provide air for cooling the equipment. Failure to provide ventilation can result in severe personal injury, death or substantial property damage.

**WARNING**

The space and combustion air supply must not contain corrosive contaminants, such as laundry products, paints, varnishes or other chemicals.

**Figure 3A** Gas orifice location

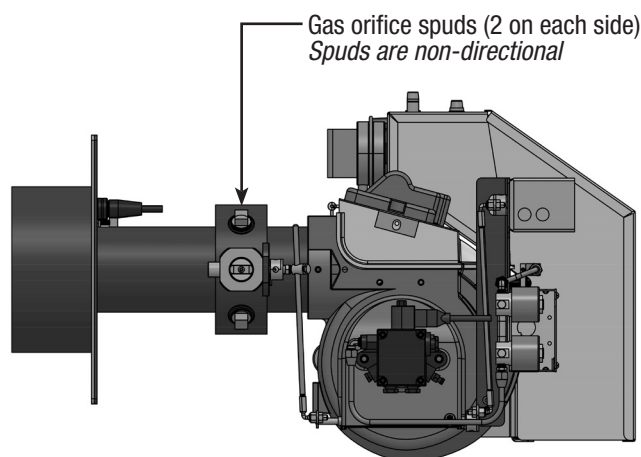

### Inspect components and wiring

- Visually inspect all burner components and wiring.
- Verify that wiring is intact and leads are securely connected.
- Verify that all burner components are in good condition.

Where appliance instructions differ from this manual, follow the appliance instructions.

## 2. Pre-fire inspection • preparation (continued)

### Install gas train on burner

1. The standard burner gas train is shipped fully assembled, with the piping disconnected at the gas train unions. See separate instructions if installing an optional knocked down gas train. The gas train is available in either an angled (standard) or straight (optional) configuration.
2. Connect the main trains at the unions (Figure 4).

**WARNING** To avoid damage to gas train components, do not hold components with a pipe wrench or overtighten. Use only a crescent wrench or other means. Failure to comply could result in severe personal injury, death or substantial property damage.

3. Connect the flexible conduit, pre-attached to the burner J-box, to the gas train J-box, and attach the wires to the terminal strip inside the gas train J-box.
  - a. Match wire colors of the incoming wires to those pre-wired to the terminal strip inside the gas train J-box.
  - b. See the label in the burner junction box or the wiring diagram on page 17.

**NOTICE** Gas valve vent opening — The V48 diaphragm gas valve is NOT fitted with a vent limiting orifice in the vent connection. If local codes require, install piping from the vent connection to outside, sized and installed as required by codes. Because this is a diaphragm-assisted solenoid valve, a small amount of gas will exit from the vent orifice each time the valve opens.

Figure 4 Gas train installation (shown with straight gas train)

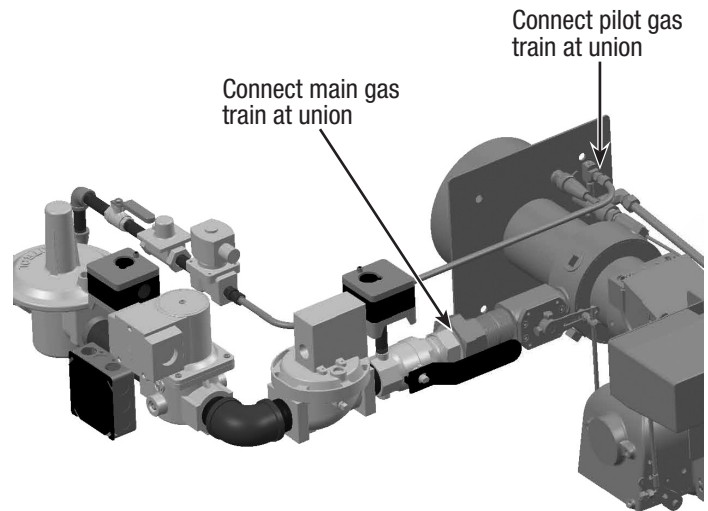
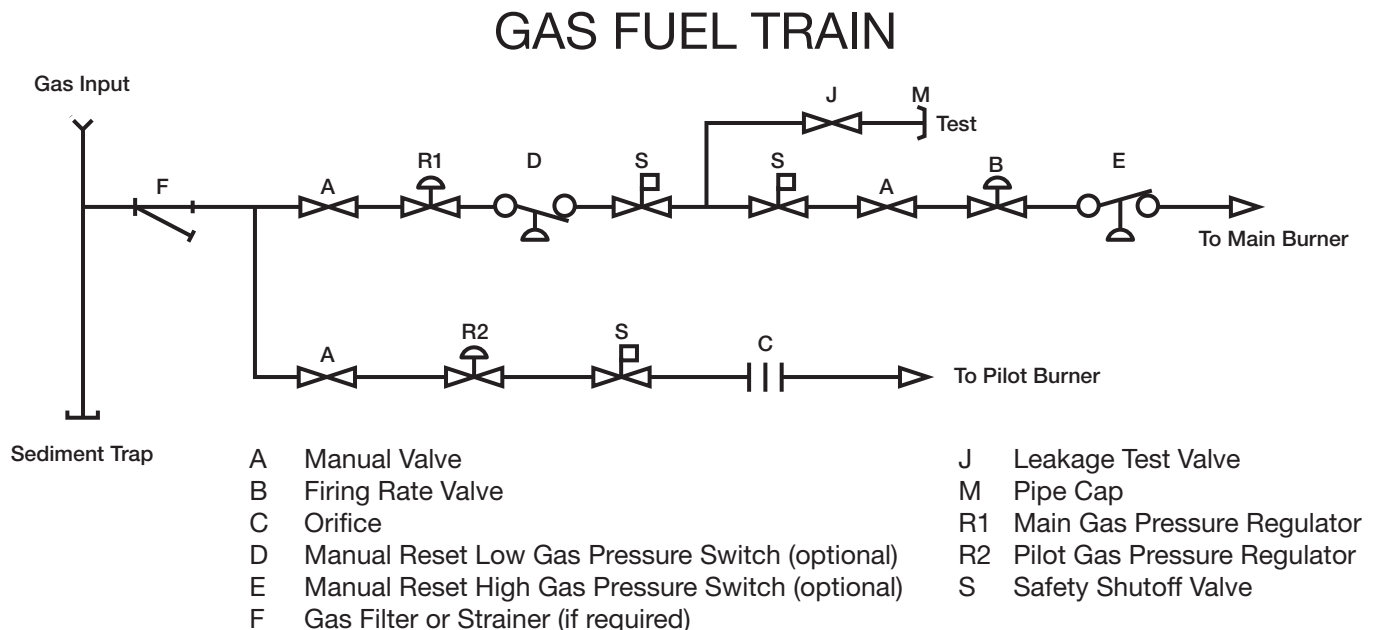

Figure 4A Gas Piping Schematic



### 3. Install gas piping

**WARNING** Connect from the gas supply to the burner gas train inlet using new, clean black iron pipe and malleable iron fittings. Do not use copper, brass, cast iron or galvanized pipe or fittings.  
 Provide support for gas piping. Do not rest the weight of the gas piping on burner gas train.  
 Provide a support for the burner gas train.  
 Apply pipe dope sparingly at all joints. Use only pipe dope listed for use with propane gas. Do not use pipe sealing tape.  
 Do not hold the gas valve with pipe wrench. Use crescent wrench or other smooth-jawed device. Do not overtighten.  
 Failure to comply with above could result in severe personal injury, death or substantial property damage.

**WARNING** Do not expose the gas train to gas pressure in excess of 14 inches water column. Higher pressure could damage the valve seat, resulting in potentially hazardous condition. When pressure testing piping at higher pressures, disconnect burner from gas line before testing.  
 If the gas supply pressure can exceed 14 inches water column at any time, you must install a lockup type gas pressure regulator in the gas supply piping, ahead of the main manual gas valve installed at the burner.

#### Piping from gas meter to burner

**NOTE:** Refer to included supplement for fuel piping schematic

1. If possible, install a new gas line directly from the gas meter. If you are using an existing gas line, verify it is clean and in good condition, and verify it is large enough to handle the load of all connected appliances.
2. When branching from a common gas line, do not tap off from the bottom of horizontal sections — only from the side or top.
3. Install a main manual shutoff valve, sediment trap and ground joint union near the burner gas train connection.
4. Size piping (or verify size) using Table 3. You will find additional information on gas line sizing in the National Fuel Gas Code, ANSI Z223.1.

Gas supply pressure — natural gas or propane

- Maximum supply pressure: 14 inches w.c.
- Minimum supply pressure: 7 inches w.c.

#### Test and purge gas line

Read WARNING above.

Pressure test and purge the line. Pressure testing should be done by the gas supplier or utility, following all applicable codes.

Figure 4A Connecting gas supply piping to burner (shown with straight gas train)

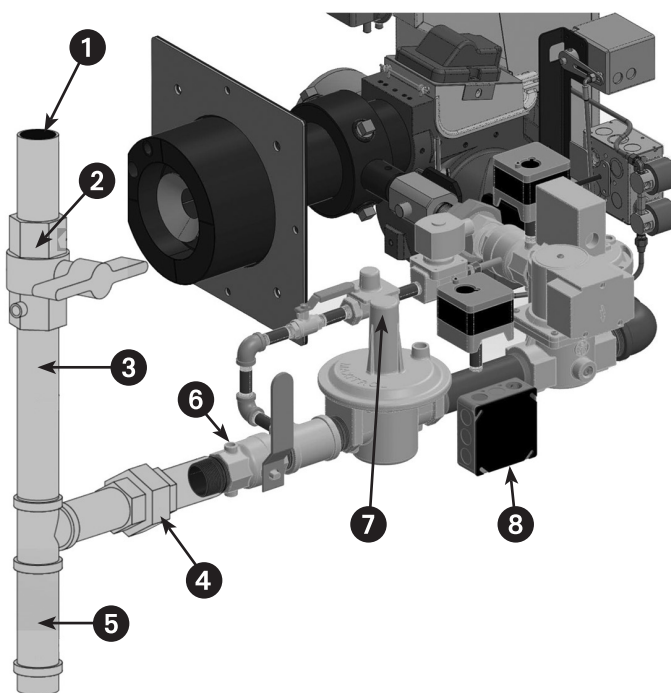

- |  |  |
|--|--|
| 1 Pipe to meter or branch  | 6 Pressure tap, 1/4" (upstream shown, outlet not shown)                                  |
| 2 T-handle main manual gas valve                                   | 7 Gas regulator access screw (the regulator spring is located under the adjusting screw) |
| 3 Use clean, burr-free black iron pipe and malleable iron fittings | 8 Gas train wire junction box  |
| 4 Ground joint union   |  |
| 5 Sediment leg   |  |

Where appliance instructions differ from this manual, follow the appliance instructions.

### 3. Install gas piping (continued)

**Table 3** Capacities of black iron pipe, cubic feet gas/hour

| <b>NATURAL GAS</b><br>Capacities in <b>Cubic feet per hour</b><br>for Schedule 40 metal pipe |  |       |       |       |       |
|--|--|-------|-------|-------|-------|
| Pipe size<br>(inches)  | Total length of gas piping,<br>from meter to burner connection (feet)  |       |       |       |       |
|  | 20   | 40    | 60    | 80    | 100   |
| <b>Natural gas @ .60 specific gravity, pressure drop 0.3 in. w.c. (note 1)</b>               |  |       |       |       |       |
| 1¼   | 730  | 500   | 400   | 350   | 305   |
| 1½   | 1,100  | 760   | 610   | 530   | 460   |
| 2  | 2,100  | 1,450 | 1,150 | 990   | 870   |
| 2½   | 3,300  | 2,300 | 1,850 | 1,600 | 1,400 |
| <b>Natural gas @ .60 specific gravity, pressure drop 0.5 in. w.c. (note 1)</b>               |  |       |       |       |       |
| 1¼   | 950  | 660   | 530   | 460   | 400   |
| 1½   | 1,460  | 990   | 810   | 690   | 620   |
| 2  | 2,750  | 1,900 | 1,520 | 1,300 | 1,150 |
| 2½   | 4,350  | 3,000 | 2,400 | 2,050 | 1,850 |
| Note 1   | For natural gas with specific gravity other than 0.60, consult National Fuel Gas Code for correction factor. |       |       |       |       |

| <b>PROPANE GAS</b><br>Capacities in <b>Btuh</b> for<br>Schedule 40 metal pipe |       |       |       |       |       |
|---|-------|-------|-------|-------|-------|
| <b>Propane gas @ 1.5 specific gravity, pressure drop 1 psi</b>                |       |       |       |       |       |
| ½   | 1,839 | 1,264 | 1,015 | 869   | 770   |
| ¾   | 3,845 | 2,643 | 2,122 | 1,816 | 1,610 |
| 1   | 7,243 | 4,978 | 3,998 | 3,422 | 3,033 |
| <b>Propane gas @ 1.5 specific gravity, pressure drop 0.5 in. w.c.</b>         |       |       |       |       |       |
| 1   | 787   | 541   | 434   | 372   | 330   |
| 1¼  | 1,616 | 1,111 | 892   | 677   | 543   |
| 1½  | 2,422 | 1,664 | 1,337 | 1,114 | 1,014 |

**Figure 5** Gas train pressure drop

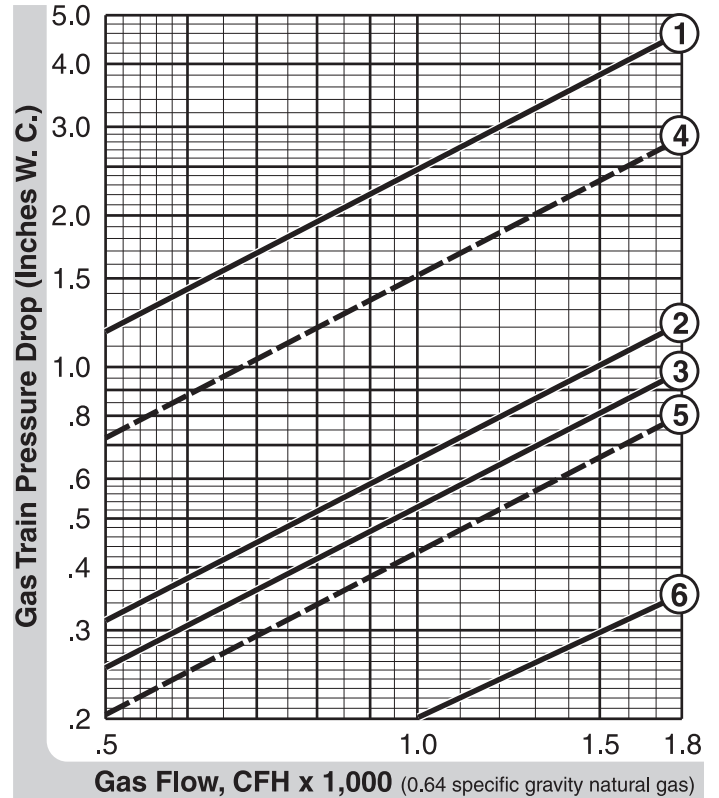

- ① 1" gas train
- ② 1¼" gas train
- ③ 1½" gas train
- ④ PROPANE: 1" gas train with RV61  
(Propane flow is NOT in CFH. Flow is in millions of Btu's/hr.)
- ⑤ PROPANE: 1¼" gas train with RV81  
(Propane flow is NOT in CFH. Flow is in millions of Btu's/hr.)
- ⑥ 2" gas train

## 4. Install oil piping

### Use two-line oil piping only

**WARNING** Use two-line oil piping only.

### Fuel unit bypass plug

**WARNING** The fuel unit is shipped with its bypass plug installed. Operating with the plug in place on a one-line system (not recommended) will damage the fuel unit and could lead to oil leakage and fire hazard.

**WARNING** If the fuel line or fuel supply is above the burner, never exceed 3 PSIG pressure at the fuel unit inlet. Install a suitable OSV to reduce the pressure. Operating the fuel unit with higher inlet pressure could result in fuel unit seal damage, oil leakage and potential fire hazard.

### Guidelines:

- When installing oil lines, use continuous runs of heavy-wall copper tubing if possible.
- Check fuel unit (oil pump) data sheet for recommended line sizing, lift limitations and maximum length.
- Check all connections and joints to ensure they are air-tight.
- Use flare fittings. DO NOT use compression fittings.
- Never use pipe sealing tape. Fragments can break off and plug fuel line components.
- Install a shut-off valve at the tank and one near the burner. (Use fusible handle design valves when possible or when required by codes.)
- Install a large capacity fuel filter (rated for 50 microns or less) near the burner.

### Inspect/install fuel supply

**CAUTION** Inspect the oil supply system. Ensure that the fuel lines are correctly sized and installed and that the fuel flow is unobstructed, the oil tank is clean and only # 1 or # 2 heating oil are supplied. Failure to supply a reliable oil flow could result in loss of heat and potential severe equipment damage.

1. See Figure 6 for typical two-line oil piping.
2. See page 15, Figures 7 and 8, for fuel unit oil flow diagrams.
3. Install the fuel unit bypass plug (two-line systems only).

### Fuel unit vacuum limitations

- See Table 4 for allowable lifts and lengths of oil lines.
- The vacuum at the fuel unit inlet port must not exceed 12 inches mercury during any operating condition.
- Attach a vacuum gauge to either of the fuel unit inlet ports, and verify the vacuum does not exceed the limit below during all firing conditions.

### Oil flow schematic / fuel unit connections

- Figure 7 shows oil flow and fuel unit port functions for Carlin 702G/O burners.
- Figure 8 applies only for optional NYC-DAR pressure regulation kits.

### Fuel supply to multiple burners

- When possible, use separate fuel supply lines for each oil burner. Using manifolded oil supply lines can create problems. If the lines are undersized, operating vacuum will exceed limits. If the lines are oversized, fuel units may have difficulty priming. Because the lines must be sized to handle the capacity of all the burners, the line size will almost always be too large when only a single burner is running.
- If manifolding cannot be avoided, carefully size the lines following the fuel units manufacturer's instructions.

Where appliance instructions differ from this manual, follow the appliance instructions.

## 4. Install oil piping (continued)

Figure 6 Two-line fuel system

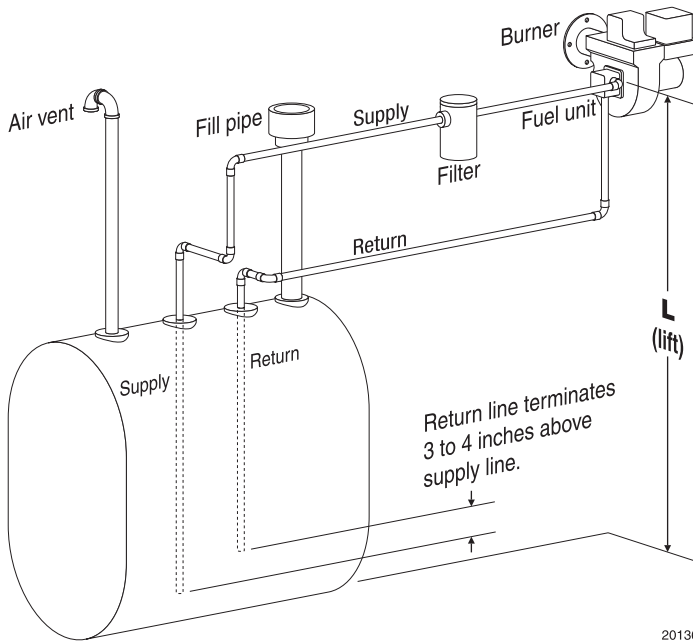

Figure 7 702G/O fuel unit and flow diagram (Low fire pressure is 100 PSIG, adjusted by screw on top of blocking valve; High fire pressure is 300 PSIG, applied when blocking valve is powered)

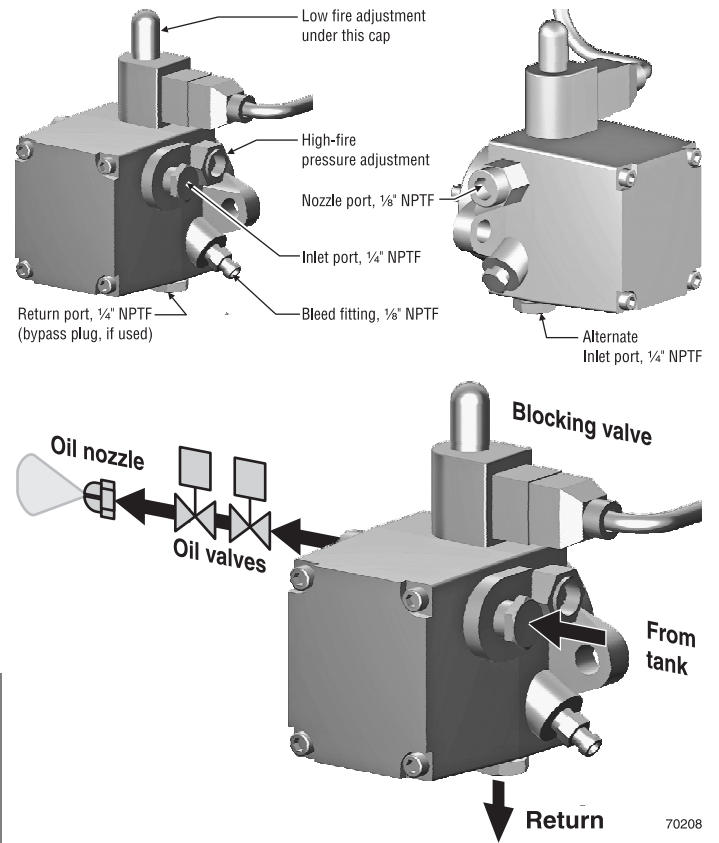
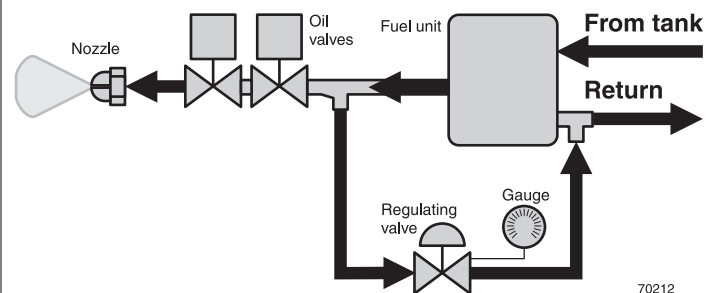

Table 4 Two-line fuel system – allowable lengths and lifts

| Lift (feet) | Length of tubing (feet) |           |
|-------------|-------------------------|-----------|
|             | 3/8" O.D.               | 1/2" O.D. |
| 0           | 41                      | 100       |
| 2           | 37                      | 100       |
| 4           | 32                      | 100       |
| 6           | 28                      | 100       |
| 8           | 24                      | 96        |
| 10          | 20                      | 80        |
| 12          | 16                      | 64        |
| 14          | —                       | 48        |
| 16          | —                       | 32        |

Figure 8 702G/O burner with NYC-DAR pressure regulation kit

**NOTICE** Obtain pressure regulator kits for New York City Department of Air Resources from Carlin. Kits must be set for the proper nozzle pressure.



## 5. Wire the burner — RM7897C primary control

**WARNING** Turn off power to appliance when servicing burner. Failure to comply could result in severe personal injury, death or substantial property damage.

**Figure 8** 702G/O burner wiring using Honeywell RM7897C primary control (see appliance manual or separate wiring information for burner equipped with a primary control not covered in this manual); see Figure 7 for a legend to callouts.

**Figure 7** Legend for Figure 8

**LEGEND**

— FACTORY WIRING  
 - - - FIELD WIRING  
 ( ) WIRE COLOR  
**R1** HIGH FIRE RELAY  
 HONEYWELL TERMINALS  
 CONTROL CABINET TEMPERATURE  
 SQN7 DAMPER MOTOR CONNECTORS  
 J-BOX TERMINALS  
 WIRE NUT/CRIMP CONNECTOR

**COLOR CODES**

|             |             |
|-------------|-------------|
| BK - BLACK  | GN - GREEN  |
| WT - WHITE  | OR - ORANGE |
| BU - BLUE   | RD - RED    |
| BN - BROWN  | VT - VIOLET |
| YL - YELLOW | GY - GRAY   |

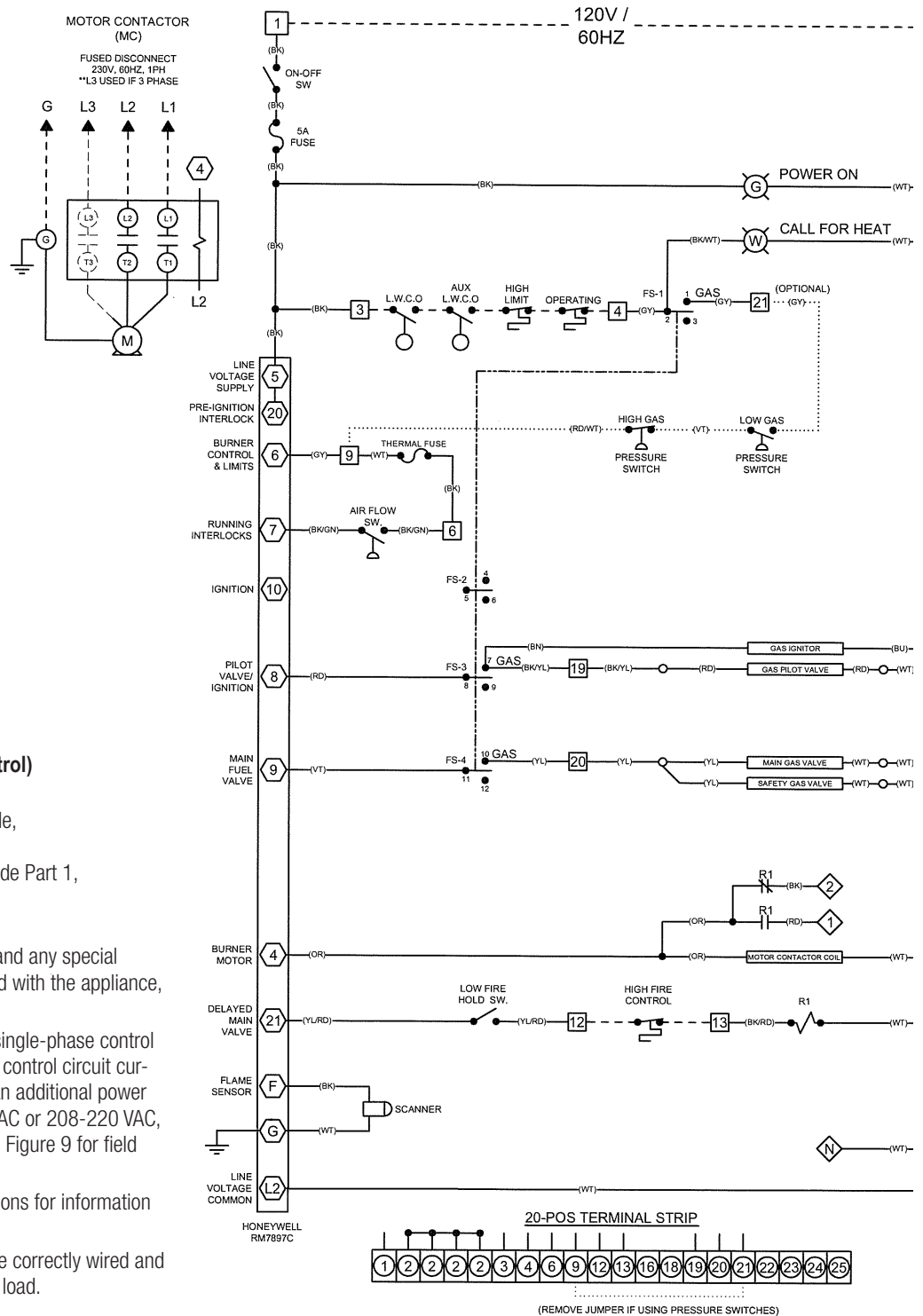

### Wire the burner (RM7897C primary control)

- All wiring must comply with:
  - In the U.S. — the National Electrical Code, ANSI Z223.1/ NFPA 54.
  - In Canada — the Canadian Electrical Code Part 1, CSA standard C22.1.
  - All applicable local codes/standards.
- Connect the burner following Figure 8 and any special instructions or wiring diagrams provided with the appliance, burner or other components.
- The burner requires a 120 VAC/60 hz/single-phase control power supply, with a 10-amp fuse. The control circuit current draw is approximately 1.2 amps. An additional power source is required for the motor (120 VAC or 208-220 VAC, 60 hz), with fuse sized accordingly. See Figure 9 for field wiring connections.
- Read the Honeywell RM7897C instructions for information on setting a room thermostat, if used.
- Make sure the burner and appliance are correctly wired and the line switch is properly fused for the load.



Where appliance instructions differ from this manual, follow the appliance instructions.

## 5. Wire the burner — RM7897C primary control (continued)

**WARNING** Turn off power to appliance when servicing burner. Failure to comply could result in severe personal injury, death or substantial property damage.

### Low-High-Low step modulation

To take advantage of the energy-saving potential of the Model 801GAS burner, it should be wired to operate at low-high-low cycles. The firing cycle can be much longer using low-high-low firing, because the burner can cycle to low fire as demand decreases. This keeps the burner on longer, reducing cyclic losses.

1. The appliance must be equipped with a high fire control. This would be a make-on-fall control, either temperature (water boiler) or pressure (steam boiler) activated. Read the appliance manual for the location of the high fire control, when used.
2. See Figures 8 and 9A to connect the high fire control to the burner firing rate circuit.
3. The burner includes a pre-wired manual high-fire switch. Close this switch to hold the burner in high fire mode. Open the switch to hold the burner in low fire mode.

**Figure 9A** 702G/O Mass Code wiring diagram (burners with RM7897C primary only); see Figure 9 for a legend to callouts

**Figure 9** Legend for Figure 9A

**LEGEND**

— FACTORY WIRING  
 - - - FIELD WIRING  
 ( ) WIRE COLOR  
**R1** HIGH FIRE RELAY  
 HONEYWELL TERMINALS  
 CONTROL CABINET TEMPERATURE  
 SQN7 DAMPER MOTOR CONNECTORS  
 J-BOX TERMINALS  
 WIRE NUT/CRIMP CONNECTOR

**COLOR CODES**

|             |             |
|-------------|-------------|
| BK - BLACK  | GN - GREEN  |
| WT - WHITE  | OR - ORANGE |
| BU - BLUE   | RD - RED    |
| BN - BROWN  | VT - VIOLET |
| YL - YELLOW | GY - GRAY   |

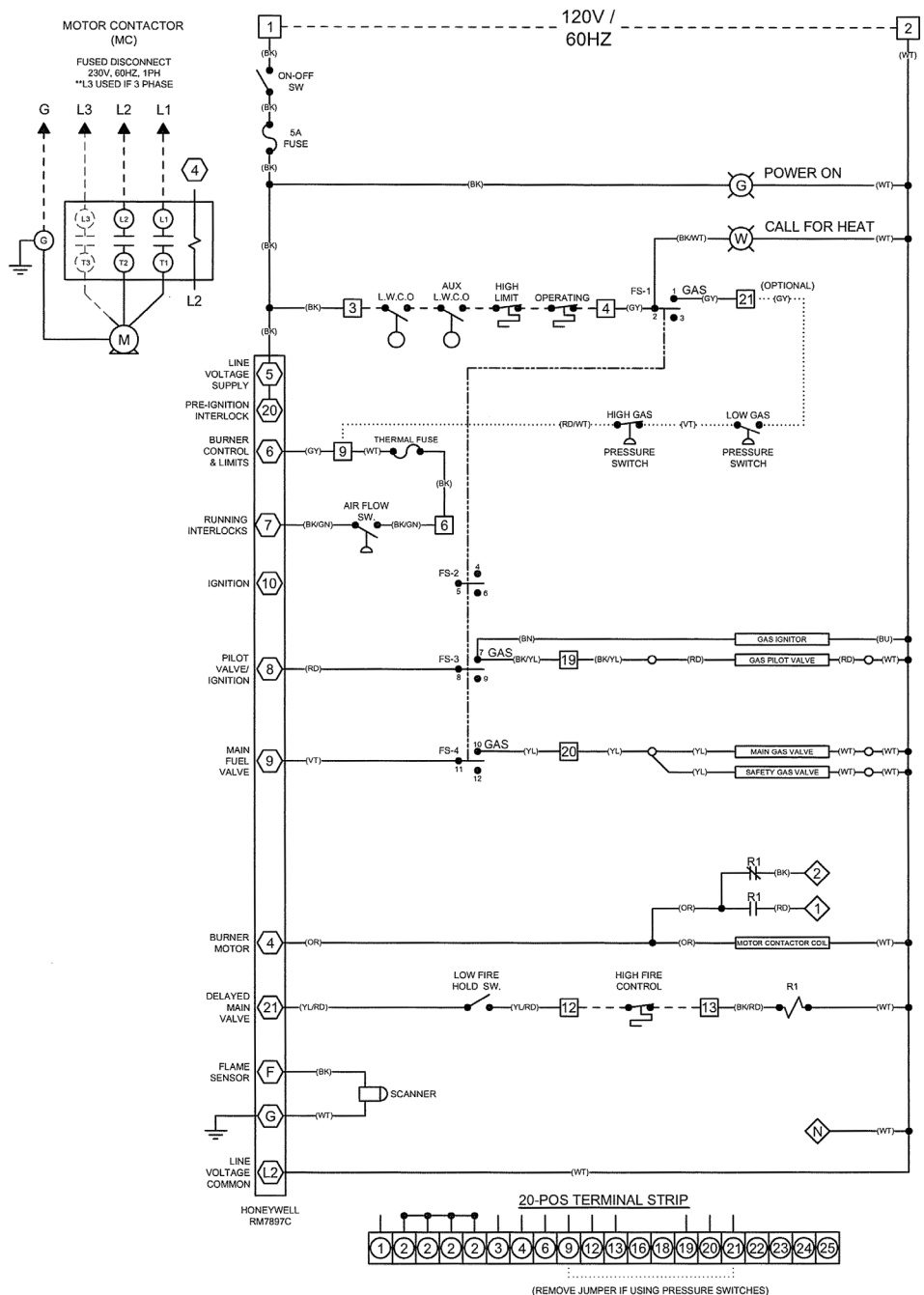

## 6. Checkout procedure — before starting the burner

### Before firing the burner . . .

**WARNING** Should overheating or an emergency occur, immediately do the following:

- Shut off oil supply line and gas supply valves.
- Under some circumstances power should remain on for water pumps or blowers. Determine proper response before attempting start-up.
- If burner fails ignition on several attempts, use burner blower to purge appliance chamber before restart.

**WARNING** If burner is running on natural gas only (no oil supply), coupling must be removed.

### Checklist before firing . . .

- Burner and appliance installed per this manual and appliance instruction manual?
- Burner/appliance installed per all applicable codes?
- Installation site has adequate combustion/ventilation air openings and vent system?
- Are voltages correct? Burner, appliance and motor correctly wired per burner and appliance manuals and wiring diagrams?

- Gas manifold spud orifices (on gas manifold, item 29, page 5) sealed with pipe dope and tight?
- Is correct nozzle installed and tightened properly?
- Gas and oil supply lines in good condition, sized and designed correctly?
- Gas and oil line connections and fittings tight?
- Oil tank has oil, and oil line valves are open. Oil supply and return lines purged?
- Burner, appliance and all components inspected and in good condition?
- Appliance limit and operating controls properly installed, wired and adjusted?
- Boiler water supply, feed pumps, automatic feeders, and low water cut-offs properly piped and wired?
- Breeching, draft regulator, draft inducer (if required) properly installed and operational?
- Gas train piping and components correctly installed, tested and verified gas tight?
- Vent lines installed when required?
- Gas lines purged?
- Sufficient gas line pressure present?
- Verify electrode settings (page 7, figure 1)

**WARNING** Follow the procedures on the following pages to ensure the burner is correctly adjusted. Take your time and the results in both gas and oil modes should result in good operation, and avoid return service calls.

You must perform the adjustments in the sequence given in this manual.

Failure to follow the correct procedures could result in severe personal injury, death or substantial property damage.

## 7. Set burner initial head and damper positions

### Before firing the burner . . .

#### Set combustion head (Dimension "A")

1. The combustion head adjusting screw is used to set the spacing between the retention ring and throttle ring (or air cone), regulating how much air passes around the retention ring.
2. See Figure 9B. Loosen the two housing cover screws. Then rotate the head adjusting ring screw until the distance from the housing detent to the beginning of the scale or scribed line equals the value given in Table 5 (Dimension "A"). Tighten the housing cover screws.

Figure 9 Set initial combustion head position

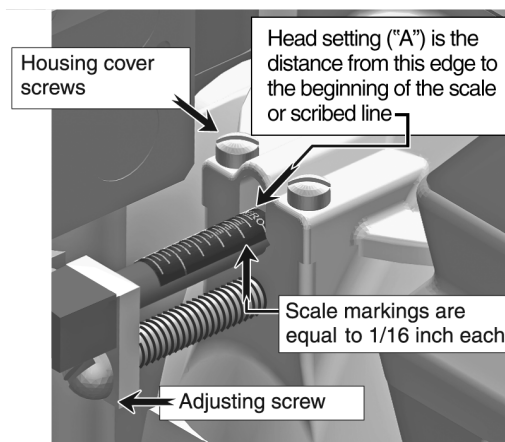

Where appliance instructions differ from this manual, follow the appliance instructions.

## 7. Set burner initial head and damper positions (continued)

### Set air damper (low fire position)

See Figure 10. Adjust the blue cam on damper motor until the air opening between the damper blade and the damper housing equals the initial low-fire opening in Table 5.

### Set air damper linkage

Make sure Air Damper Linkage is set at 3/4" from the top of the Damper Motor and the bottom of the linkage screw (see Figure 10A). If your settings are off, loosen the two hex head screws found on the linkage arm bosses at the top and bottom of the Air Damper Linkage. Adjust the linkage accordingly, then tighten screws to set position.

Figure 10A Set air damper linkage

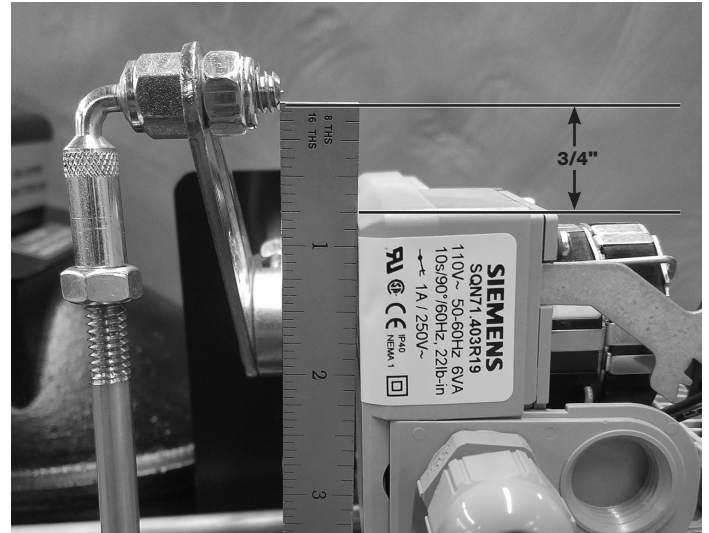
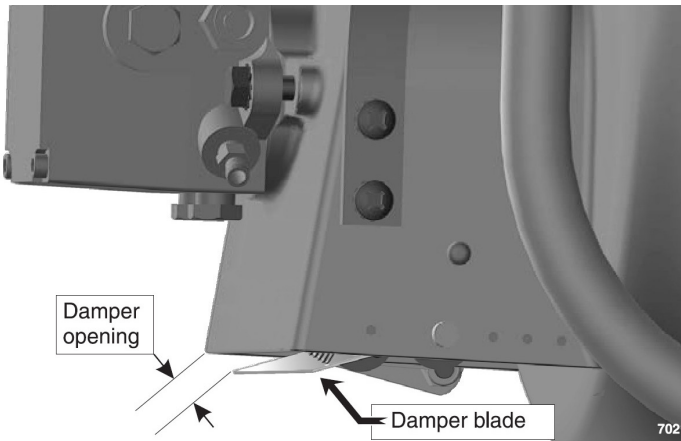

Figure 10 Set initial low fire air damper setting



### Determining final adjustments

The burner is now adjusted to the **approximate** air settings for the firing rate used. Follow the procedures on the following pages to **use test instruments** and make final burner adjustments.

Table 5 Initial burner settings (see the pages 18 through 22 for final adjustments using test instruments)

| Low-fire Input                                    |                    | High-Fire Input                                   |                    | Combustion head position<br>Dimension "A"<br>Inches (approximately) | Air damper low-fire opening<br>Inches (approximately) | Siemens Blue Cam Settings | Butterfly valve open – low fire (factory set)<br>% (approximately) |
|---|--------------------|---|--------------------|---|---|---------------------------|--|
| # 2 Fuel Oil<br>GPH @ 100 PSIG<br>(Nozzle Rating) | Natural Gas<br>MBH | # 2 Fuel Oil<br>GPH @ 100 PSIG<br>(Nozzle Rating) | Natural Gas<br>MBH |   |   |                           |  |
| 3.50  | 490                | 6.00  | 840                | 0   | 3/8   | 25                        | 30   |
| 3.75  | 525                | 6.50  | 910                | 1/16  | 3/8   | 25                        | 30   |
| 4.00  | 560                | 6.90  | 966                | 1/8   | 7/16  | 27                        | 30   |
| 4.50  | 630                | 7.80  | 1092               | 3/16  | 7/16  | 27                        | 30   |
| 5.00  | 700                | 8.70  | 1218               | 3/8   | 1/2   | 30                        | 30   |
| 5.50  | 770                | 9.50  | 1330               | 5/8   | 1/2   | 30                        | 30   |
| 6.00  | 840                | 10.40   | 1456               | 1-1/8   | 9/16  | 35                        | 30   |
| 6.50  | 910                | 11.20   | 1568               | 1-3/8   | 9/16  | 35                        | 30   |

| Nozzle Specifications | Standard   | Hago 45° SS                   |
|-----------------------|------------|-------------------------------|
|                       | Alternates | Hago 45° P<br>Monarch 45° PLP |

## 8. Adjust the burner using test instruments

**WARNING**

The settings given in Section 6 are initial settings only. **You must use test instruments** to check combustion, and adjust the burner as necessary, following the procedures given in the following pages of this manual. Failure to properly adjust the burner can result in severe personal injury, death or substantial property damage.

### Adjustment procedure, summary

- Step 1:** Set high-fire oil airflow by adjusting the combustion head. See details following.
- Step 2:** Adjust the air damper for low-fire oil. See details following.
- Step 3:** Adjust the damper motor end switch (only if necessary). See details following.
- Step 4:** Set gas pilot operation. See details following.
- Step 5:** Set high-fire gas flow to match high-fire air. See details following.
- Step 6:** Adjust the butterfly valve linkage to match low-fire gas to low-fire air. See details following.
- Step 7:** Verify operation of burner, appliance, and controls.

### Use test instruments

1. Use combustion test equipment and an accurate manometer or draft gauge to correctly set the burner as required.
2. Overfire pressure must not exceed the appliance manufacturer's recommendations. The burner must never be fired at an overfire pressure more than 0.60 inches w.c.

**NOTICE**

When the overfire pressure is positive, the maximum burner firing rate is reduced. The firing rate is also reduced for altitudes higher than 2000 feet above sea level. See page 3 for rating information. Ensure that the oil nozzle selected is correct the required firing rate.

3. Adjust the burner fuel and air settings using the following procedures. When adjustment has been completed, the CO<sub>2</sub> (or O<sub>2</sub>) should be within the ranges in Table 6, at both low fire and high fire.

**Table 6** Allowable values of CO<sub>2</sub> and O<sub>2</sub>

| Fuel        | CO <sub>2</sub> |         | O <sub>2</sub> |         |
|-------------|-----------------|---------|----------------|---------|
|             | Minimum         | Maximum | Maximum        | Minimum |
| #2 Fuel Oil | 10.5 %          | 12.5 %  | 6.6 %          | 3.9 %   |
| Natural Gas | 8.5 %           | 10.0 %  | 6.2 %          | 3.6 %   |
| Propane     | 9.5 %           | 11.2 %  | 6.0 %          | 3.5 %   |

### Start the burner (firing on oil)

**WARNING**

Do not start the burner if the combustion chamber contains oil or oil vapor.

1. Turn service switch OFF.
2. Perform inspections and checkouts on page 12.
3. Verify burner is set according to page 13.
4. Slip one end of a 3/16-inch I.D. clear plastic hose over the end of the fuel unit bleed valve, the other end into a container. Then open bleed valve.
5. Set burner fuel selector switch to OIL.
6. Set thermostat (operating controls) to call for heat.
7. Turn service switch ON.
8. Burner motor, fuel unit and blower should turn on.
9. Bleed the oil line until the plastic line is free of bubbles; then another 15 seconds longer. (Should the primary control timing cause a lockout during purging, restart the burner following the primary control data sheet instructions.)
10. Close the bleed valve. The burner should cycle through the sequence given in the primary control data sheet.
11. Should control/burner fail to operate correctly, shut burner off immediately and check burner settings and fuel supplies.
12. Operate burner for 15 minutes before making final adjustments using test equipment.
13. Check for leaks in fuel piping.

**WARNING**

Inspect fuel piping system for leaks. Repair any leaks to avoid fire hazard from oil leakage or combustion problems due to air infiltration into oil.

14. Inspect the flame

- Look at the flame through the appliance combustion chamber observation port, if available. The flame should be well-defined and should not impinge on any appliance surface. (If you make air changes later, inspect the flame again.)

**WARNING**

**Do not attempt to confirm combustion simply by inspecting the flame visually. You must use combustion test instruments.** Failure to properly verify/adjust combustion could allow unsafe operation of the burner, resulting in severe personal injury, death or substantial property damage.

15. Insert the combustion equipment test probe into a vent sample opening to sample flue products.

**WARNING**

All installations should be checked after one to two weeks of operation to ensure the appliance/burner units are operating correctly.

Where appliance instructions differ from this manual, follow the appliance instructions.

## 8. Adjust the burner using test instruments (continued)

### NOTICE

The linkage between the damper motor arm and the air damper crank is set at the factory, and should ONLY need adjustment if the damper motor or the damper rod is replaced. With the burner in high-fire position, there should be minimal play in the connecting rod. DO NOT change this linkage setting.

### Step 1 (firing on oil)

#### Set combustion head (Dimension "A")

1. Allow the burner to operate approximately 15 minutes to ensure the appliance is heated and combustion is steady.
2. Set the draft as specified in the appliance manual.
3. The combustion head adjusting screw is used to set the spacing between the retention ring and throttle ring, regulating how much air passes around the retention ring. (See Figure 5, page 13.) The larger the value of dimension A, the larger the clearance, so the larger the airflow. The smaller the value of dimension A, the smaller the airflow.
4. Measure the %CO<sub>2</sub> in the appliance flue. The value should be approximately 12.5% for high fire oil. If the CO<sub>2</sub> is higher than 12.5%, adjust the head adjusting screw (see Figure 5, page 13) to a larger dimension A to increase airflow. If the CO<sub>2</sub> is less than 12.5%, adjust the screw to a smaller dimension A to decrease airflow.
5. Reset draft as specified in the appliance manual, after any airflow adjustment.
6. Check the smoke value in the appliance flue. It must be zero to a trace. If not, try increasing airflow (reducing the CO<sub>2</sub>). If increasing airflow increases smoke, the combustion is probably on the wrong side of the CO<sub>2</sub> curve. To correct, increase the airflow until the smoke is eliminated.
7. When adjustments are completed, the CO<sub>2</sub> must be between 12.0% and 12.5% at high fire oil, with smoke equal to zero or a trace. Overfire draft must be -.02 inches w.c., or as specified in the appliance manual.

### Step 2 (firing on oil)

#### Set low-fire damper

1. Flip the low-fire switch to low fire.
2. The burner fuel unit blocking valve will be deactivated, and the oil nozzle pressure will drop to 100 PSIG.

3. See Figure 6, page 13. Adjust the low-fire damper screw until the low-fire CO<sub>2</sub> is between 11% and 12%. Rotate the screw clockwise to increase airflow (reduced CO<sub>2</sub>). Rotate the screw counterclockwise to decrease airflow (increase CO<sub>2</sub>).
4. Smoke at low fire must be zero or a trace. Note that too much air can actually increase smoke.

### Step 3 (firing on oil)

#### Damper actuator end switch position

See included supplement MNSQN71 for visual callouts and instructions on setting Damper Actuator.

1. Modulate the burner from low fire to high fire and back to low fire, pausing at each step for about one minute.
2. If the swing from low fire to high fire is rough (burner bangs or rumbles), or the fire is very smoky, the damper actuator end switch may be in the wrong position. High-fire oil should pull in as the air damper is about halfway through its swing.
3. For different appliance applications, it is sometimes necessary to have high-fire oil pressure earlier or later than normal during the swing to achieve a smoother, cleaner transition.
4. If the swing is rough (flame goes out, bangs or rumbles), there could be air in the oil, or the nozzle may be defective. Check, and replace the nozzle if necessary. Then retry.
5. If the fire is too lean, the flame could lift off of the head, causing rumble or unsteady combustion. In this case, adjust the modulating motor end switch to energize **earlier**.
6. If the flame is very smokey, adjustment to the switching points may need to be made.
  - Adjustments of the switching points are done by means of adjustable cams
  - Scales beside the cams indicate the angle of the switching point
  - Assignment of cams to the end of auxiliary switches is color-coded
  - Some of the cam feature fine adjustment they can be adjusted with a standard screwdriver
  - The other cams can be adjusted manually or with a hook-spanner or similar tool
7. Restart the burner and check modulation again. Continue with 1 through 6 above as needed until results are acceptable.

Turn off the burner when Step 3 is completed before proceeding with setup for gas combustion, Step 4.

## 8. Adjust the burner using test instruments *(continued)*

**WARNING** Check all joints with a soap suds mixture or electronic gas leak detector to ensure the gas train and all components are tight and leak-free. Shut down the burner and correct any leak immediately. Failure to comply could result in severe personal injury, death or substantial property damage.

### Step 4 *(firing on gas)* Check gas pilot operation

**NOTICE** The Model 702G/O uses a gas pilot for ignition of the gas main flame. The gas pilot is ignited by the pilot electrode. The butterfly gas valve is factory set to a preliminary setting of 30% open for low fire, and 100% open for high fire.

1. After completing Steps 1, 2 and 3 on page 19, move the burner fuel selector switch to GAS. Set the low-fire switch to low fire.
2. Make sure the gas line has been completely bled. Then turn the service switch to ON.
3. The pilot will usually light the first time once the pilot gas train has been completely purged of air.
4. The pilot flame is approximately 70 MBH. If the pilot fails to light, be sure the gas line has been bled properly. If the primary control is equipped with a pilot test hold switch, it can be used to hold the pilot "on" while adjusting pilot gas pressure.
5. Follow the instructions in the primary control instruction manual to check flame signal. Make sure the flame signal is steady, and greater than the required minimum for the UV sensor.
6. Check and ensure that the bent ignitor (Figure 11) is approximately centered in pilot assembly. If not, loosen electrode locking nut, rotate assembly and tighten nut.
7. To check static pressure on pilot air, drill a #60 hole in the pilot air tube (red circle, Figure 12) and use a manometer for the reading. Pressure must be more than .45" w.c.

Figure 11 *Pilot Spark Gap*



### Step 5 *(firing on gas)* Set main gas pressure regulator

**NOTICE** The butterfly gas valve is factory set to a preliminary setting of 30% open for low fire, and 100% open for high fire. The pilot regulator is set for 3.0 inches w.c. Use monometer in the pilot test port (Figure 12) provided to confirm settings.

1. Leave the low-fire switch in low fire.

Figure 12 *Pilot Test Port*

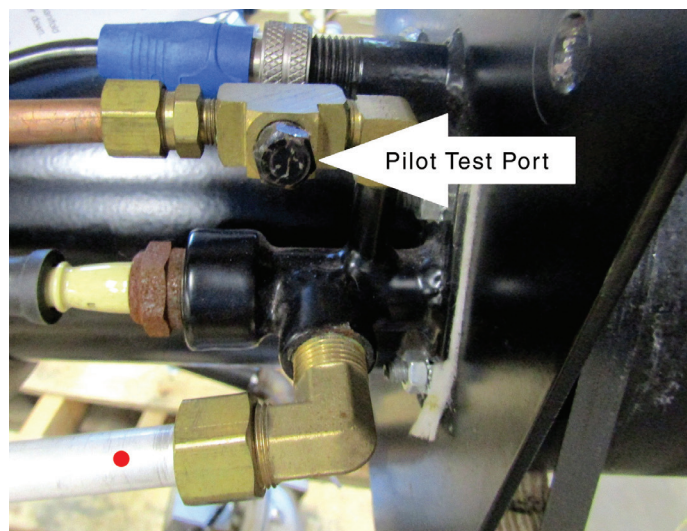

2. With the gas pilot operating correctly, and the UV sensor flame signal above minimum required, the primary control will cycle the burner to main gas.
3. Check the flame signal after the pilot has shut down to ensure the signal is still strong with main flame on.
4. Move the burner fuel selector switch to OFF. The burner will shut down.
5. Temporarily install two U-tube manometer connections to check gas pressures. Install connections at the inlet pressure tap of the main manual gas valve and at the downstream pressure tap of the manual gas valve next to the butterfly valve.
6. The gas pressure at the inlet to the gas train must never exceed 14 inches w.c., either when the burner is off or firing on gas.
7. Move the burner fuel selector switch to GAS. The burner should start.
8. With the burner firing in low fire, check the gas pressure at the downstream of the butterfly valve. Adjust the main gas pressure regulator if necessary until the gas pressure reads 1.0 inch w.c. as a starting pressure.
9. Switch the low-fire switch to high fire. **CAUTION:** Be prepared to turn the burner off immediately if it begins to pulsate as it attempts to move to high fire.
10. If the flame pulsates, it is probably too rich. Switch the low-fire switch to low fire and reduce the gas pressure by adjusting the main gas pressure regulator. Then return to 9, above.
11. If the fire is too lean, it will appear small and can even blow out during the swing to high fire. If it blows out, shut off the burner immediately. Switch the low-fire switch to low fire and start the burner again. Adjust the main gas pressure regulator to increase the gas pressure. Return to 9, above.

**WARNING** With the burner running in high fire, inspect the butterfly valve indicator (Figure 13). The indicator must be at 90°. IF NOT, turn the burner off. Loosen the two hex-head screws securing the valve linkage arm. With the damper motor linkage arm pulled up, use a screwdriver to rotate the butterfly valve slot until it is horizontal. Tighten the two hex head screws while still holding the damper motor linkage arm up. Return to step 9, above. DO NOT proceed with combustion adjustment unless the butterfly valve position has been verified, and corrected if necessary.

Where appliance instructions differ from this manual, follow the appliance instructions.

## 8. Adjust the burner using test instruments (continued)

12. With the burner running in **high fire**, adjust the main gas pressure regulator to achieve:
  - Natural gas: 9.6% to 10.0% CO<sub>2</sub>.
  - Propane: 10.7% to 11.2% CO<sub>2</sub>.
  - Measure the CO content. It should be no greater than 100 PPM.

**NOTICE** High CO readings may indicate the combustion is on the wrong side of the CO<sub>2</sub> curve. You will know this if a decrease in gas pressure causes an increase in CO<sub>2</sub>.

### Step 6 (firing on gas) Set butterfly gas valve linkage

1. Switch the low-fire hold switch to low fire.
2. Check CO<sub>2</sub> and CO. The CO<sub>2</sub> should be between 9.0% and 10.0% (natural gas) or between 10.0% and 11.2% (propane); with CO less than 100 PPM.
3. To adjust the low-fire air (change CO<sub>2</sub>), move the burner fuel selector switch to OFF. Adjust the butterfly gas valve linkage as described in the following to change the low-fire gas flow to the burner head. Do not change the main gas pressure regulator setting.
4. **DO NOT ADJUST THE LOW-FIRE AIR DAMPER SETTING.** This must be left as set for oil firing.
5. See Figure 13 for location of linkage components.

Figure 13 Butterfly gas valve linkage

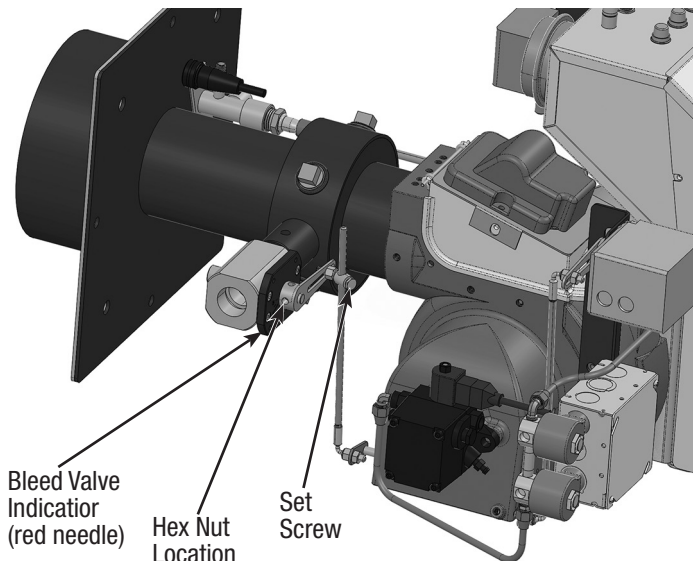

**NOTICE** To adjust the linkage, loosen set screw in the adjustable link in small increments. A 1/8-inch move can cause CO<sub>2</sub> to change as much as 1.5%.

- If more gas is needed (to increase CO<sub>2</sub>), slide linkage UP.
  - If less gas is needed (to decrease CO<sub>2</sub>), slide linkage DOWN.
6. Tighten the set screw in the adjustable link.

7. **The butterfly valve indicator must be at 90°.** IF NOT, turn the burner off. Loosen the two hex-head screws securing the valve linkage arm. Rotate the butterfly valve indicator until it is at 90°. Disengage actuator motor. Rotate linkage to high fire. Tighten the two hex head screws while still holding the motor linkage arm in high fire. Rotate linkage to low fire. Re-engage pin.
8. Tighten the two hex head screws on the butterfly valve linkage arm boss.
9. Restart and repeat as necessary until CO<sub>2</sub> and CO are acceptable.

**IF EQUIPPED WITH LOW-HIGH GAS PRESSURE SWITCH, PROCEED TO STEP 6A. OTHERWISE PROCEED TO STEP 7.**

### Step 6a (firing on oil and on gas) Verify operation

**NOTICE** Perform all of the checkout procedures given in Step 6 of the burner manual. In addition, verify operation of the gas pressure switches as described below.

#### Verify high gas pressure switch operation

- Cycle the burner off with the appliance controls and turn off power to the appliance/burner.
- Attach a manometer to the manifold-side manual gas valve test port.
- Turn on power and cycle the burner on with the appliance controls.
- Measure the manifold gas pressure with the manometer.
- Set the high gas pressure switch to a pressure less than actual manifold pressure. The high gas pressure switch should shut the burner down. Replace the switch if necessary.
- Turn off power to the appliance/burner; remove the manometer and replace the plug in the gas valve test port. Reset switch.

#### Verify low gas pressure switch operation

- Cycle the burner off with the appliance controls and turn off power to the appliance/burner.
- Close the main manual gas valve.
- Cycle the burner on.
- The low gas pressure switch should shut the burner down. Replace the switch if necessary.
- Turn off power to the appliance/burner.
- Open the main manual gas valve.
- Reset low gas pressure switch.

## 8. Adjust the burner using test instruments **(continued)**

### Step 7 **(firing on oil and on gas)**

#### Verify operation

##### Burner/appliance/controls operation

- Test operating and limit controls on appliance as specified in appliance instructions.
- Check operation of the primary control by forcing lockout to occur. For primary controls that enter latch-up after multiple lockouts, force latch-up to occur as well. Reset primary control per control data sheet instructions after each test.
- Start and stop the burner several times, allowing the primary control to sequence through normal operation. Verify correct operation of burner and primary control throughout on both oil and gas.
- Confirm and/or adjust overfire combustion pressure for oil and gas operation. Refer to boiler/furnace manufacturer's recommendations.

##### Verify vent system operation

- Verify vent is operating correctly and flue products are properly exhausted from building. If the building contains any exhaust fans or conditions that could affect vent performance, check burner/appliance/vent operation with exhaust fans (or other conditions) operating.

##### Combustion/ventilation air

- Verify combustion/ventilation air openings are not, and will not be obstructed.
- Verify air opening louvers are fully open.
- If louvers are motor-operated, verify motor and end switch are interlocked with appliance/burner wiring to prevent operation of the burner if the air louvers are not fully opened.

##### Prepare burner for normal operation

- Cycle burner off with appliance controls.
- Turn off power to the appliance.
- Seal the appliance flue test opening.
- Verify all components and wires are in place and burner is ready for operation.
- Restore power to the appliance.

##### Train the user

- Train the user to operate the burner and appliance under normal conditions.
- Explain the procedure to shut down the burner/appliance when required.
- Review the back cover of this manual (and the appliance manual) with the user.
- Verify the user is aware of all procedures specified in the manuals.
- Verify that the user will not store or use combustible liquids or materials or contaminants in the vicinity of the burner/appliance.



Where appliance instructions differ from this manual, follow the appliance instructions.

## 9. Maintenance and service procedures

### When servicing the burner . . .

- DISCONNECT ELECTRICAL SUPPLY and all other electrical connections to burner before attempting to service to avoid electrical shock or possible injury from moving parts.
- CLOSE all manual gas and oil valves before disconnecting any portion of fuel lines and before cleaning or removing any parts from the burner or related equipment.
- Burner and appliance components can be extremely hot. Allow all parts to cool before attempting to handle or service to avoid potential of severe burns.

**WARNING** Turn off power to appliance when servicing burner. After servicing, always operate burner/appliance to verify all components are functioning correctly and that the burner is properly adjusted. Failure to comply could result in severe personal injury, death or substantial property damage.

### General maintenance

#### Cleaning blower wheel

1. The blower wheel accumulates dust and debris from normal operation. You will need to clean the wheel blades periodically to prevent reduction in airflow. Inspect the blower wheel regularly by opening the housing cover.
2. To clean blades, when necessary, remove the bolts securing the motor to the blower housing.
  - a. Slide the motor out and rotate to remove and access blower wheel.
  - b. Use a brush and vacuum to clean each blade and the blower housing interior.
  - c. Install motor/wheel in blower housing and secure with the two bolts.
  - d. Push wire slack back into junction box.

#### Replacing blower motor or wheel

1. If either the blower wheel or motor must be replaced, remove the bolts securing the motor to housing.
2. Disconnect the motor wires in the burner panel.
3. Loosen the Allen screw securing the blower to the motor shaft and remove the wheel.
4. When assembling the replacement assembly, slide the wheel onto the motor shaft and use feeler gauges to set space between the blower wheel and the motor face. This space must be 3/16 inch.
5. Install the motor/wheel assembly in the housing, wire the motor leads and secure the motor with the two bolts.

### Motor maintenance

- Refer to motor manufacturer's instructions for oiling the motor as needed.

### Checking ignitor

**WARNING** Never test an ignitor by placing a screwdriver (or other metallic object) across the high voltage clips. This could cause ignitor damage or severe personal injury.

1. Checking 45000 ignitors only:
  - Disconnect electrical power to burner.
  - Open the burner access cover and remove ignitor wires from the electrodes. Lightly clamp each ignitor wire to the burner housing, with the wire ends pointed toward one another, spaced apart by a 1/2" to 3/4" gap.
  - Energize ignitor and check for spark arcing at the high voltage terminals. If spark jumps the gap, ignitor is good.

### Thermal fuse

1. When the burner is in a high-overfire draft condition, and not properly adjusted, it is possible that the flame could flash back inside the air tube. If this occurs, the thermal fuse will open in less than two seconds. The fuse must be replaced. (The burner is supplied with spare fuses.)

## 9. Maintenance and service procedures (continued)

### Annual start-up and service

**WARNING** This burner must be started and serviced at least annually by a qualified service technician. Failure to properly maintain and service the burner could result in severe personal injury, death or substantial property damage.

- Discuss burner/appliance operation with user to determine any problems that may have occurred during the previous season and to verify user is aware of proper operation and care of the burner/appliance.
- Review proper operation of the appliance/burner unit with the user.
- Turn off power to appliance.
- Remove combustion head assembly to clean and adjust if necessary.
- If the inside surface of the air tube and/or retention ring need to be cleaned, clean them with a vacuum cleaner with brush attachment while the combustion head assembly is out of the burner.
- Inspect and adjust the ignition electrodes and insulators per instructions on page 10 of this manual. Replace if proper spacing cannot be achieved or if components are damaged.
- Close the housing cover plate and secure in place.
- Inspect the fuel line oil filter. Replace if necessary.

**NOTICE**

Oil line filters — Use a non-bypassing filter to prevent nozzle plugging caused by poor oil filtration. Non-bypassing filters prevent small foreign particles from bypassing the filter, a common problem with fiber element type filters. Another problem of some filters is the fiber from filter element tears can break away and plug the nozzle or fuel unit.

- Perform the complete checkout procedures of pages 16, including system inspection and checks.
- Inform the user of any problems found.

Where appliance instructions differ from this manual, follow the appliance instructions.

## 9. Maintenance and service procedures (continued)

| <b>Installation/service certificate</b>   |  |  |                            |   |                         |
|---|--|--|----------------------------|---|-------------------------|
| <b>Installation data</b>  |  |  |                            |   |                         |
| Burner model  | Serial number  | Measured gas firing rate, Btuh   | Oil nozzle size & pattern: | Manifold gas pressure, IWC (High fire/Low fire) | Inlet gas pressure, IWC |
| CO <sub>2</sub> %<br>Oil Low Fire: _____<br>Oil High Fire: _____<br>Gas Low Fire: _____<br>Gas High Fire: _____ | O <sub>2</sub> %<br>Oil Low Fire: _____<br>Oil High Fire: _____<br>Gas Low Fire: _____<br>Gas High Fire: _____ | Nozzle pressure:<br>• High fire: _____ PSIG • Low fire: _____ PSIG<br><br>Fuel unit vacuum ("Hg)<br>• High fire: _____ InHg • Low fire: _____ InHg |                            | Were limit controls tested?                     |                         |
| Comments about installation/start-up:   |  |  |                            |   |                         |
| Installer's name:   | Company name:  | Company address:   |                            | Phone:  |                         |
| <b>Service history</b>  |  |  |                            |   |                         |
| Date  | Technician   | Company/address  | Describe work performed    |   |                         |
|   |  |  |                            |   |                         |
|   |  |  |                            |   |                         |
|   |  |  |                            |   |                         |
|   |  |  |                            |   |                         |

Where appliance instructions differ from this manual, follow the appliance instructions.

For parts not shown or listed, contact factory and/or check separate documentation supplied with appliance/burner unit.

## 10. Repair parts — Burner housing and components

| ITEM | PART NO.  | DESCRIPTION  | 702G/O |
|------|-----------|--|--------|
| 1    | 27706S    | Motor: 1/2 hp, 115/230V, 60HZ, 1 Phase, 3450 rpm                           | •      |
| 2    | 98507S    | Electorde Set of 2, Approx. 9 1/4" OAL                                     | •      |
| 3    | 55772S    | Ignition wire (One wire in Service Pack) (2 Req'd)                         | •      |
| 4    | 51562S    | 14" Tube with pressurized flange 1" main gas inlet; external pilot, 4" UTL | •      |
| 5    | 98522S    | Air Flow Switch 120 Volt   | •      |
| 6    | 51573S    | Gasket   | •      |
| 7    | 51317S    | Damper Motor - SQN71   | •      |
| 8    | 40857S    | Instant Oil Valve 32Z0071TSCV  | •      |
|      | 41004S    | Instant Oil Valve 32Z0078TSCV 3 Way  | •      |
|      | 61150KITS | Oil Valve Kit (44560, 29678, 44461, 29728, 44545)                          | •      |
| 9    | 23556S    | Suntec, 2 Stage, B2TA-8851   | •      |
|      | 74476S    | Suntec, 2 Stage, NYC, B2TA-8851 100/300PSI                                 | •      |
| 10   | 51451BS   | 14" Combustion Head Assembly (includes thermal fuse and electrode wire)    | •      |
|      | 51575BS   | 14" Combustion Head Assembly for 702GAS                                    |        |
|      | 51459S    | Butterfly Valve and Crank Arm-Siemens VKG-10, 1"NPT                        | •      |
| 11   | 4180002FS | Gas Ignitor  | •      |
|      | 45000S    | Oil Ignitor  | •      |
|      | 45000SOLC | Ignitor on Baseplate   | •      |

| ITEM | PART NO.  | DESCRIPTION  | 702G/O |
|------|-----------|--|--------|
| 12   | 98857KITS | Blower Wheel, Coupling, Augmentor, 6 1/2" OD x 3 3/4" W, 1/2" Bore   | •      |
| 13   | 98856S    | Coupling, 1/2" ID x 5/16" ID x 6 13/16" L, B Pump                    | •      |
| 14   | 56747S    | Retention Ring Assy 702CRD   | •      |
| 15   | 75358KITS | Oil Line Kit For 702G/O  | •      |
| 16   | 35824S    | Motor Contactor 20 AMP R4242B1005 (not shown)                        | •      |
| 17   | 51476S    | Shutter Drive Link Kit 9"  | •      |
|      | 51542S    | Damper Motor Linkage Kit 11"   | •      |
| 18   | 34215S    | Thermal fuse   | •      |
|      | 99716S    | Toggle Switch (Not Shown)  | •      |
| 19   | 35311S    | C7027A1023 UV Scanner  | •      |
|      | 97656S    | Q7800B1003 Sub Base  | •      |
|      | 99766S    | RM7897C1000 Programming Control                                      | •      |
|      | 97662S    | R7849A1023 Amplifier   | •      |
|      | 97716S    | ST7800A1054 Timing Card  | •      |
|      | EMX51UVS  | EMX51UV KIT includes all of the above                                | •      |
| 20   | 23382S    | Pedestal (Not Shown)   | •      |
| 21   | 6702KITS  | Hardware Kit (Yoke 54916, C/H adj screw 47167, oil line elbow 29694) | •      |
| 22   | 51202S    | Pilot assembly with ignitor and gasket                               | •      |
|      | 51376S    | Gas/Oil Pilot Ignitor  | •      |

Where appliance instructions differ from this manual, follow the appliance instructions.

For parts not shown or listed, contact factory and/or check separate documentation supplied with appliance/burner unit.

## 10. Repair parts — Burner housing and components (continued)

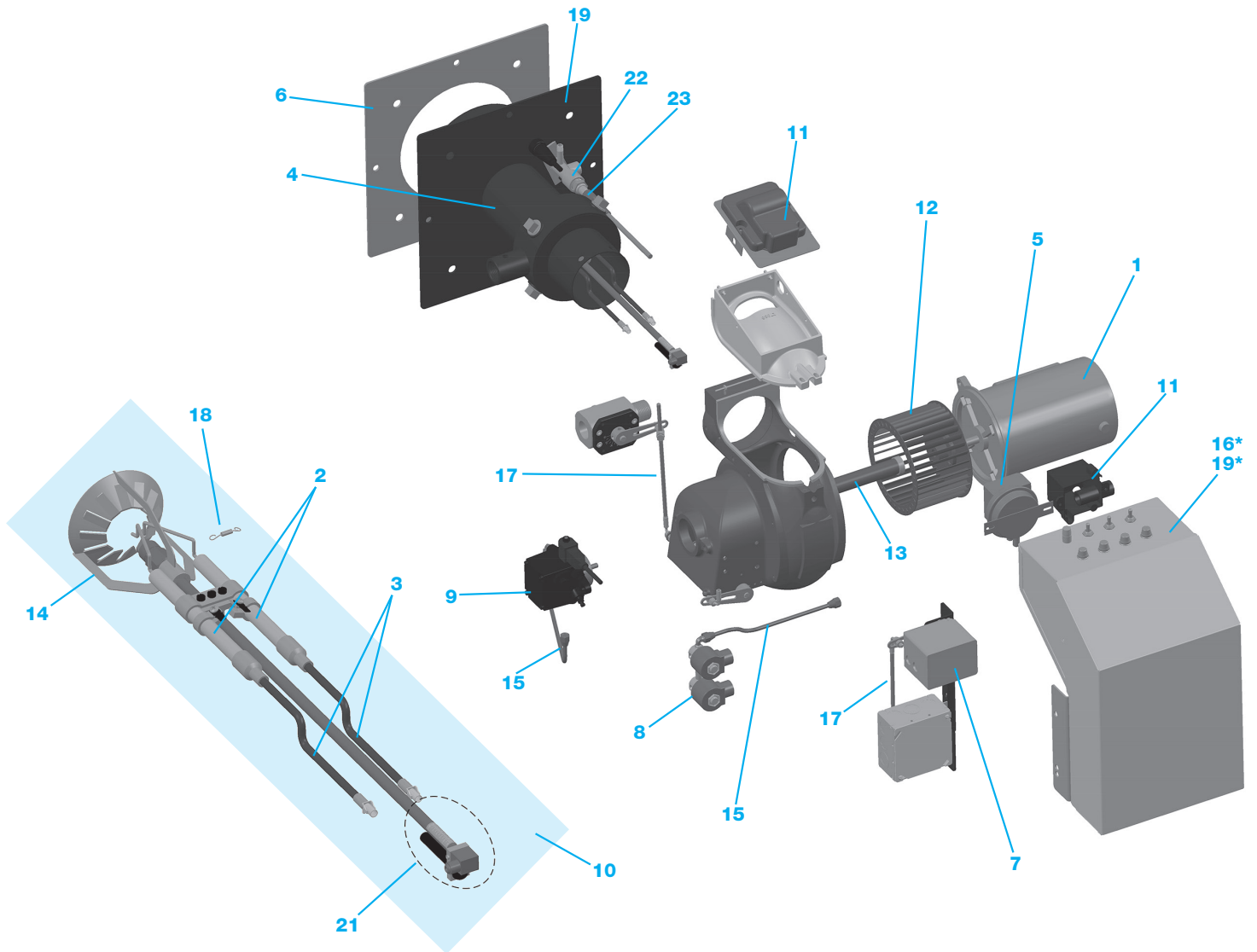

Where appliance instructions differ from this manual, follow the appliance instructions.

For parts not shown or listed, contact factory and/or check separate documentation supplied with appliance/burner unit.

## 10. Repair parts (continued)

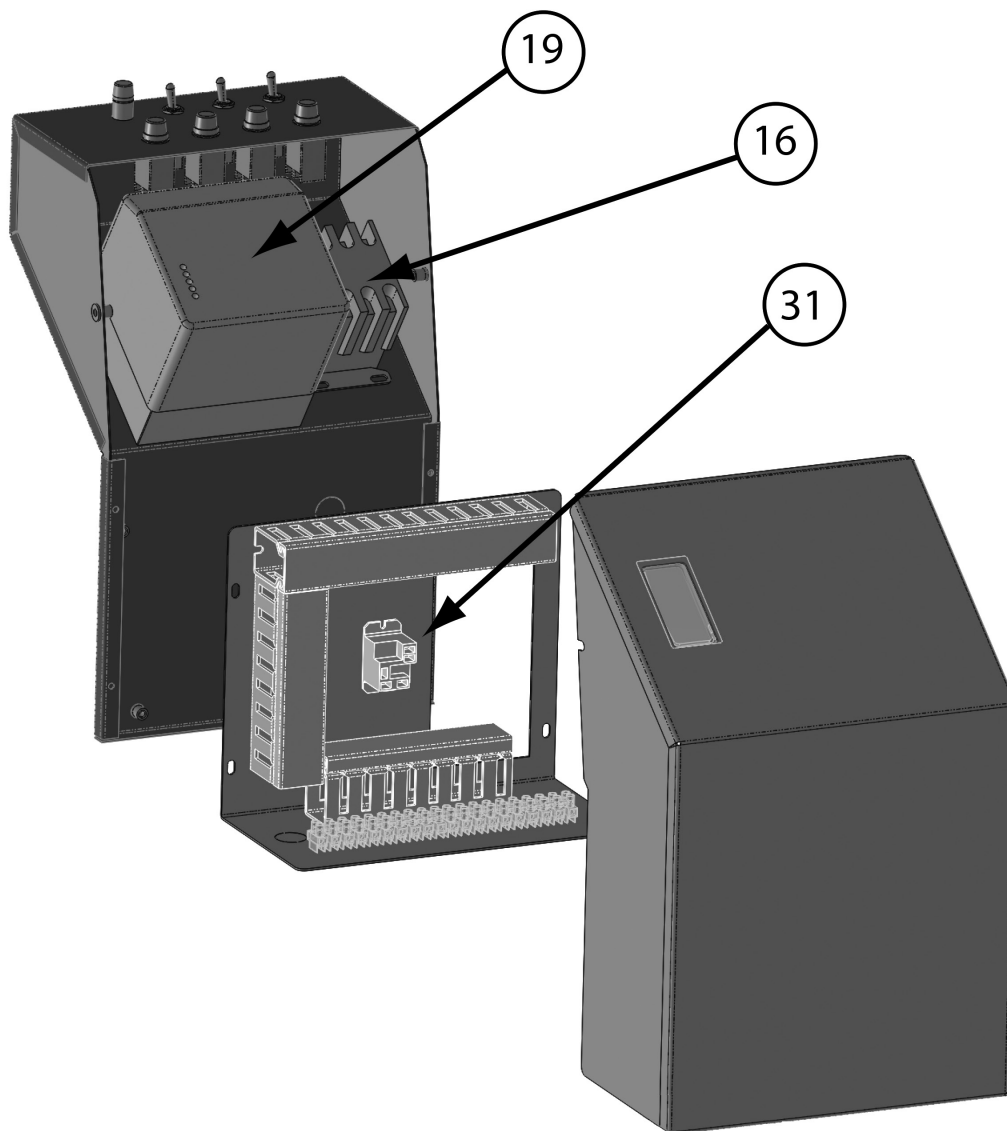

|    |          |   |
|----|----------|---|
| 16 | 35824S   | Motor Contactor 20 AMP R4242B1005 (not shown) |
| 19 | EMX51UVS | EMX51UV KIT includes all of the below         |
|    | 35311S   | C7027A1023 UV Scanner                         |
|    | 97656S   | Q7800B1003 Sub Base                           |
|    | 99766S   | RM7897C1000 Programming Control               |
|    | 97662S   | R7849A1023 Amplifier                          |
|    | 97716S   | ST7800A1054 Timing Card                       |
| 31 | 51512    | Relay-SPDT                                    |

Where appliance instructions differ from this manual, follow the appliance instructions.

## 11. Dimensions

Figure 10 Dimensional data, burner only

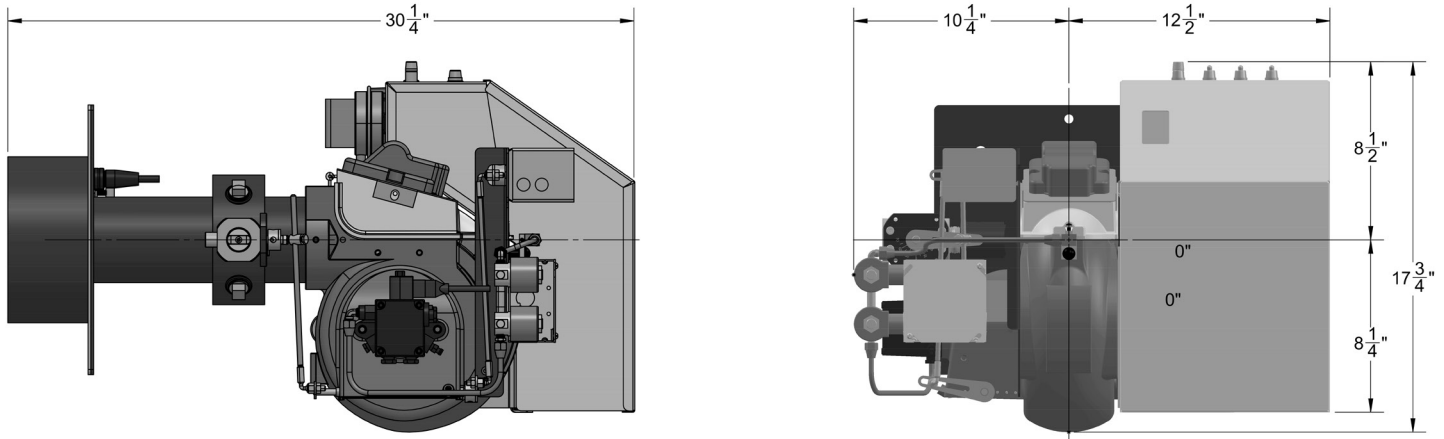
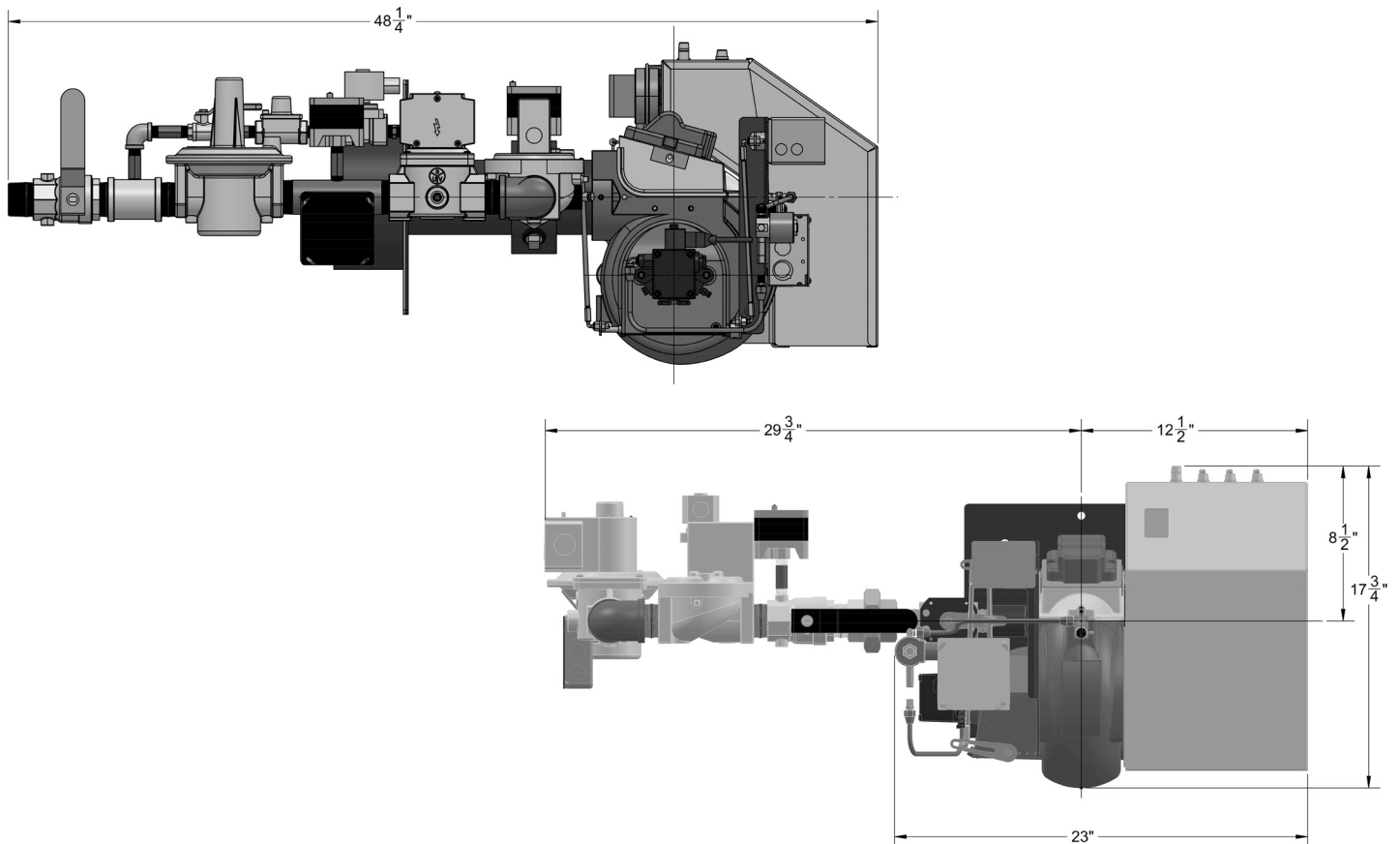
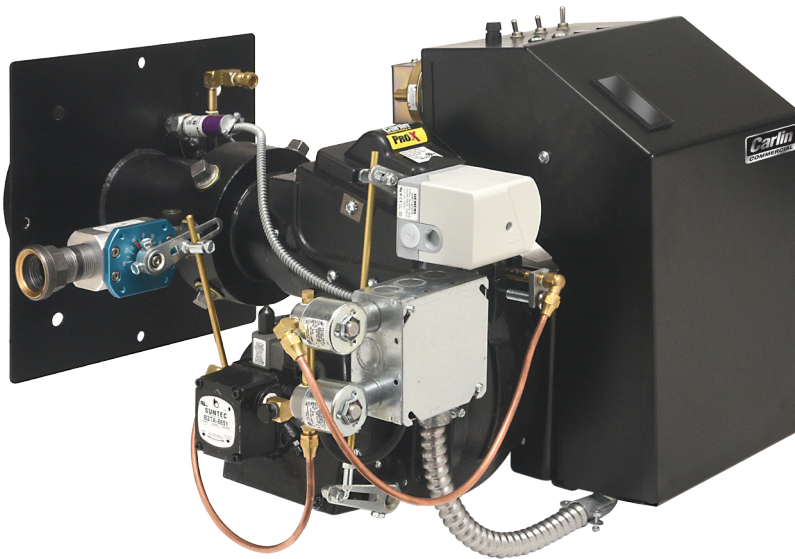

Figure 10A Dimensional data, burner with gas train





## 702G/O Burner



**WARNING** The burner must be cleaned, tested and adjusted annually by a qualified burner service technician.

**WARNING** **Should overheating occur:**

- (1) Shut off both fuel supplies to the burner.
- (2) **DO NOT** shut off the control switch to the circulator or blower.
- (3) Contact your oil dealer or service technician and the fire department (if needed).

### User care and maintenance

**WARNING** Refer only to the information on this page, intended for your use. The remainder of this manual is intended only for your service technician. Failure to comply could result in severe personal injury, death or substantial property damage.

For other than routine maintenance, contact a qualified service company. Perform the following as needed.

- Keep the area around the burner clear and free from combustible vapors and liquids.
- Do not obstruct the flow of combustion and ventilating air.
- Most motors currently used on residential type burners use permanently-lubricated bearings, and do not require field lubrication. Read the label on the motor to determine oiling needs, if any. Do not over-lubricate. This can cause as much trouble as not lubricating at all.

**WARNING** Never attempt to use gasoline as a fuel for this burner, as it is more combustible and could result in a serious explosion. Never attempt to burn refuse or use any fuel other than # 1 or # 2 heating oil (ASTM D396).