



MODEL 801G/OTM Advanced Combination Gas/Oil Burners

Low-High-Low Step Modulating

Low Rate (51600A)

10.4 to 15 GPH Oil
1400 to 2100 MBH Gas

High Rate (51600B)

15 to 17 GPH Oil
2100 to 2500 MBH Gas

(High-fire input capacities)

Instruction Manual

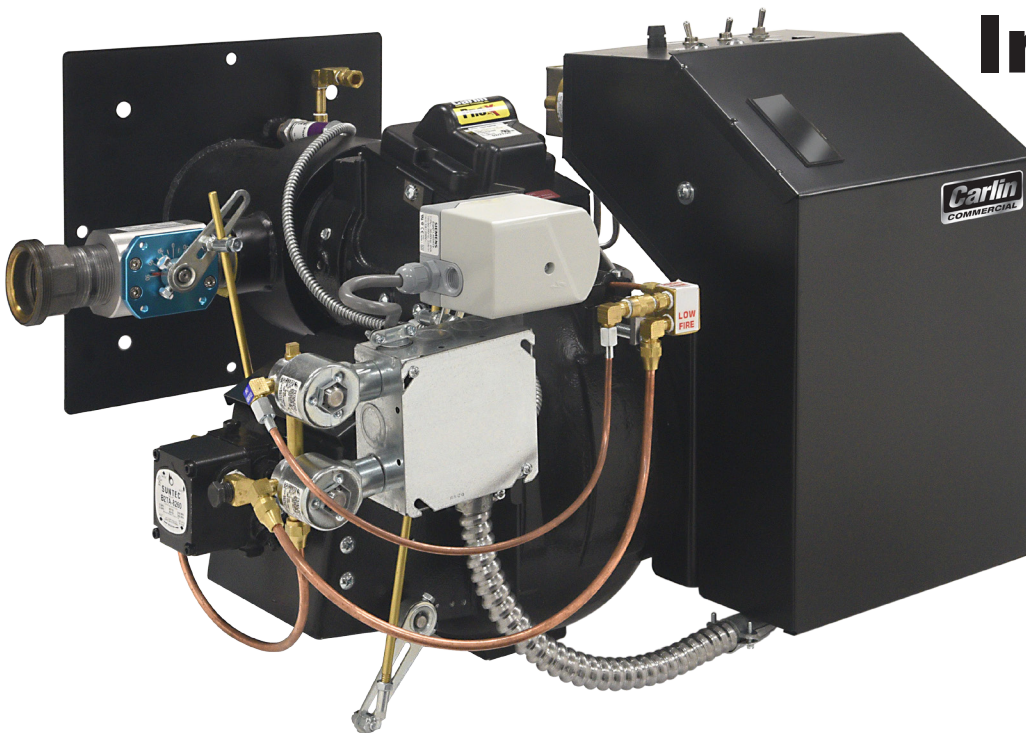

WARNING

Except where specifically stated otherwise, this manual must be used only by a qualified service technician.

In the state of Massachusetts, this product must be installed by a licensed Plumber or Gas Fitter.

Failure to comply with the above or other requirements in this manual could result in severe personal injury, death or substantial property damage.

WARNING

USER — Refer only to User care and maintenance on back page for information regarding operation of this burner. The burner Instruction Manual is intended only for your service technician. The burner and heat exchanger must be inspected and started at least annually by your service technician.

WARNING

Check burner cartons carefully. The Model 801G/O combination gas/oil burner was assembled and tested at the factory before shipment. If the burner was ordered with a completed assembled gas train, the train was pressure tested and electrically checked for proper operation. Where possible, the gas train or components were shipped in the same carton as the burner. Check your packing slip for the number of cartons shipped from the factory.

© Copyright 2021 — Carlin Combustion Technology

Carlin Combustion Technology

126 Bailey Road
Ph 203-680-9401

North Haven, CT 06473
Fx 203-680-9403

TECH SUPPORT 800-989-2275

carlincombustion.com

PLEASE read this first . . .

Contents

| | |
|---|------------|
| PLEASE read this first..... | 2 |
| General information..... | 3 |
| 1. The Carlin Model 801G/O combination gas/oil burner | 4 |
| 2. Prepare site • assemble burner • mount burner | 6 |
| 3. Install gas piping..... | 12 |
| 4. Install oil piping..... | 14 |
| 5. Wire the burner..... | 16 |
| 6. Checkout procedure – before starting the burner..... | 18 |
| 7. Set burner initial head and damper positions | 18 |
| 8. Adjust the burner using test instruments | 20 |
| 9. Maintenance and service procedures | 25 |
| 10. Dimensions..... | 28 |
| 11. Repair parts | 30 |
| 12. SQN71 damper motor adjustment..... | 32 |
| User care and maintenance | Rear cover |

Special attention flags . . .

Please pay particular attention to the following when you see them throughout this manual.

DANGER Notifies you of hazards that WILL cause severe personal injury, death or substantial property damage.

WARNING Notifies you of hazards that CAN cause severe personal injury, death or substantial property damage.

CAUTION Notifies you of hazards that WILL or CAN cause minor personal injury or property damage.

NOTICE Notifies you of special instructions on installation, operation or maintenance that are important, but are not normally related to injury or property damage hazards.

Before installing or servicing:

WARNING Should overheating occur:
(1) Shut off the oil and gas supplies to the burner.
(2) DO NOT shut off the control switch to the boiler circulator or the burner.

WARNING Follow the guidelines below to avoid potential severe personal injury, death or substantial property damage.

Installer/service technician . . .

- Read all instructions before proceeding. Perform all procedures, and in the order given to avoid potential of severe personal injury, death or substantial property damage.
- Before leaving the site after startup or service, review the User care and maintenance page with the user. Make the user aware of all potential hazards and perform the training outlined below.

Installer/service technician — Train the user . . .

- To properly operate the burner/appliance per this manual and the appliance instructions. See User care and maintenance.
- To keep this manual at or near the burner/appliance for ready access by the user and service technician.
- To contact the service technician or oil dealer if he encounters problems with the burner/appliance.
- To keep the appliance space free of flammable liquids or vapors and other combustible materials.
- To never use laundry products, paints, varnishes or other chemicals in the room occupied by the burner/appliance.
- To contact the service technician at least annually for startup and burner/appliance service.

When servicing the burner . . .

- DISCONNECT ELECTRICAL SUPPLY and all other electrical connections to burner before attempting to service to avoid electrical shock or possible injury from moving parts.
- CLOSE all manual gas and oil valves before disconnecting any portion of fuel lines and before cleaning or removing any parts from the burner or related equipment.
- Burner and appliance components can be extremely hot. Allow all parts to cool before attempting to handle or service to avoid potential of severe burns.

General information

Burner applications

Setup can be dramatically different when working with over fire pressure applications. Follow all instructions in this manual, the primary control data sheet and the appliance manual.

Verify the burner is correct for the appliance being used and for all applicable codes/standards.

Setup can be dramatically different when working with over fire pressure applications. Adjust the nozzle selection/firing rate if necessary due to positive overfire pressure and/or altitudes more than 2,000 feet above sea level. See the NOTICE under the Ratings information at right. Where appliance application information is available, the recommended firing rate and burner information will include appropriate adjustments for positive overfire pressure and recommendations for high altitudes. Follow the appliance manual guidelines when available or visit Carlincombustion.com to view a digital copy of our OEM Setup Tables.

Damage or shortage claims

The consignee of the shipment must file damage or shortage claims immediately against the transportation company. See the NOTICE on page 1 for burner carton information.

When calling or writing about the burner:

Please provide us with the UL serial number and burner model number to assist us in locating information. This information can be helpful when troubleshooting or obtaining replacement parts.

Codes and standards

Certification

801G/O burners are U.L. listed for the U.S., certified to comply with:

- ANSI/UL 296, for use with #1 or #2 heating oil including bio blends not exceeding B20 (U.S ONLY) (per standard ASTM D396).
- UL 295, for use with natural gas or propane.
- Burner labels list compliance, when required, with special local, state or provincial approvals.

NOTICE

Install this burner in accordance with all local codes and authorities having jurisdiction. Regulations of these authorities take precedence over the general instructions provided in this manual.

United States installations

Burner/appliance installations in the United States must comply with the latest editions of:

- Installation of Domestic Gas Conversion Burners, ANSI Z21.8.
- National Fuel Gas Code, ANSI Z223.1/NFPA 54.
- Standard for the Installation of Oil-Burning Equipment, NFPA 31
- National Electrical Code, ANSI/NFPA 70.
- All additional applicable national, state and local codes.

NOTICE

The 801G/O burner, configured for Massachusetts Code compliance, differs from the standard 801G/O in:

- 1 Low and high gas pressure switches are added to the gas train.
- 2 Jumper JR2 on the primary control is clipped and removed, causing the control to be non-recycling.

Ratings

(With 0.00" w.c. overfire pressure, altitude 2,000 feet max.; see NOTICE below)

Oil Input

..... Low Rate (51600A): 10.4 to 15 GPH
 High Rate (51600B): 15 to 17 GPH

Gas Input

..... Low Rate (51600A): 1400 to 2100 MBH
 High Rate (51600B): 2100 to 2500 MBH

Fuels

..... No. 1 or No. 2 Fuel oil including Bio Blends not exceeding B20 (U.S ONLY)
 Natural gas or propane

Fuel unit & oil valves:

..... Fuel unit, 2-stage, 150 psig
 (2) Oil solenoid valves

Gas train: (available in straight or angled configuration)

..... (2) Main gas valves & RV-81 regulator
 Butterfly gas valve for input regulation
 1 1/2" gas train standard; 2" gas train available

Electrical

Power..... 120 vac/60 hz/1-PHASE
 Limit circuit input..... 120 vac/60 hz
 Control circuit load (120 vac)..... 1.2 AMPS
 Motor..... 3/4 hp, 3450 rpm, 56C-frame
 115 / 208-230 vac/60 hz/1-ph, 9.8 / 4.8-4.9 amps
 Opt: 208-230 / 460 vac/60 hz/3-ph, 3.0-3.2 / 1.6 amps
 Oil valve power..... 120 vac/60 hz
 Damper motor (with end switch)..... Siemens SQN71

Ignition & primary control

Gas: Carlin Model 41800 Solid State Ignitor
 Ignition Voltage..... 9000 volts
 Oil: Carlin Model 45000 solid state ignitor
 Ignition Voltage..... 14000 volts
 Primary control..... Honeywell RM7897C
 Alt: Fireye MEC120

Agencies UL Listed (US)

NOTICE

Reduce nozzle/firing rate when required – Maximum burner capacity is reduced when overfire pressure is positive and for altitudes above 2,000 feet. See below, and adjust firing rate/nozzle selection if necessary.

801G/O – Maximum firing rate for positive overfire pressure and high altitude

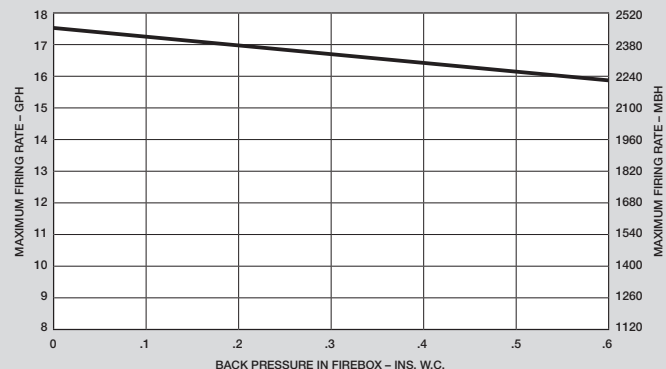

Altitudes: For altitudes more than 2,000 feet above sea level, reduce the above capacities an additional 4% per 1,000 feet higher than 2,000 feet above sea level.

1. The Carlin Model 801G/O combination gas/oil burner

801G/O overview

The Model 801G/O combination gas/oil burner is a low-high-low (step modulating) burner that utilizes a damper motor to control air (and gas fuel rate). Fuel is selected using the Gas/oil changeover switch. The burner operates on either #2 fuel oil or gas (natural or propane).

See the next page for gas train component locations.

Gas mode operation

Ignition for main flame is accomplished by a proved gas pilot of approximately 75,000 Btuh. Pilot gas is introduced at the side of burner airtube assembly and is ignited by a Carlin 9,000-volt electronic ignitor wired to the electrode. After the pilot flame is proven, the two main gas safety valves open. The pilot gas valve closes after a time delay to allow main flame to establish. Flame is monitored both for pilot flame and main flame with a UV scanner mounted to the side of the burner air tube assembly. The burner main flame begins at low fire. If additional input is required, the damper motor opens the gas butterfly valve and air damper to their high fire positions.

Gas is introduced into the burner through a manifold around the air tube. The gas then circulates through a set of four orifice spuds into the air stream, upstream of the retention ring. The spin of the air flow at the retention ring thoroughly mixes the gas/air before it reaches the combustion zone.

Oil mode operation

Oil ignition is accomplished by the Carlin 14,000-volt electronic ignitor wired to the two electrodes. The oil flame begins at low fire, with 150 PSIG oil pressure at the first nozzle. The damper motor opens the air to the high fire position. The damper motor end switch energizes the 2nd stage oil valve providing 150 PSI oil to the second nozzle. Flame is monitored by the UV scanner.

Automatic fuel changeover

If your 801G/O is equipped for use with an Outside Temperature Switch, please see included supplement MNAFCO.

Firing rate adjustment

NOTICE High Fire MUST be set before Low Fire

- Firing rate is determined by the oil nozzles. Air flow is matched to the oil flow for oil firing. Then gas flow is adjusted to match the air flow at low and high fire rates. High fire must be set before low fire.
- See the "Starting and operating" section of this manual for the complete description of the adjustment process. The following is a brief summary only.
- High-fire air is set by adjusting the combustion head position (to control air flow through and around the retention ring).
- Low-fire air is then adjusted by fine-tuning the position of the low fire damper adjusting screw.
- Pilot gas flow is set for a smooth light-off. Then gas inputs are adjusted for good combustion at low and high-fire air settings.

801G/O oil nozzles

NOTICE Use the selections below when the heating equipment manufacturer's specific nozzle selection data is not available, either in the equipment manual or the Carlin OEM Spec Guide. Follow all instructions provided with the appliance.

Nozzle specifications

- Preferred — Hago 45° H
- Alternate — Delavan 45B or 45A

Nozzle ratings

Full input (low and high fire) occurs at 150 PSIG nozzle pressure. Since nozzles are rated at 100 PSIG, the actual flow at 150 PSIG is approximately 22% higher than the rated nozzle capacity. See the table below for nozzle rating selections.

Table 1 801G/O oil nozzles

| NOZZLE DATA AND COMBUSTION HEAD SETTINGS | | | | | |
|--|-----------|------------------------------------|-----------|---|------|
| Nozzle Specifications Hago Products Corp. | | Oil Delivery Rate GPH @ 150 PSI | | "A"* Approximate Retention Ring Setting On Scale | |
| 1st Stage | 2nd Stage | Low Fire | High Fire | Low Fire Air Shutter | |
| 5.50 | 3.00 | 6.60 | 10.40 | 1/16" | 0 |
| 5.50 | 4.00 | 6.60 | 11.40 | 1/16" | 1/4" |
| 5.50 | 4.50 | 6.60 | 12.00 | 1/16" | 1/4" |
| 5.50 | 5.00 | 6.60 | 12.60 | 1/48" | 1/4" |
| 5.50 | 5.50 | 6.60 | 13.20 | 3/16" | 1/4" |
| 6.00 | 5.50 | 7.20 | 13.80 | 1/4" | 3/8" |
| 6.00 | 6.00 | 7.20 | 14.40 | 5/16" | 3/8" |
| 6.00 | 6.50 | 7.20 | 15.00 | 3/8" | 3/8" |
| 6.50 | 6.50 | 7.80 | 15.60 | 7/16" | 1/2" |
| 6.50 | 7.00 | 7.80 | 16.20 | 1/2" | 1/2" |
| 6.50 | 7.50 | 7.80 | 16.80 | 3/8" | 1/2" |
| 6.50 | 8.00 | 7.80 | 17.40 | 3/4" | 1/2" |

1. For a packaged appliance application on which the burner has been tested, use the nozzle given in the appliance manufacturer's instructions or supplement for the best results.

Gas pressure requirements

The 801G/O burner requires 3.4" w.c. minimum pressure at the butterfly valve during high fire. Select a gas train that has a pressure drop no more than the available pressure at the gas train inlet minus the 3.4" needed at the butterfly valve. See page 13 for gas train pressure drop information. The burner is equipped with a 1½" gas train unless a larger gas train is ordered.

Example: A boiler has an input rating of 2,500,000 Btuh. Gas pressure available at the gas train entrance is 6.0" w.c. Subtract 3.4" from the available 6.0" w.c. The gas train pressure drop must be 2.6" or less. A 1½" gas train has a pressure drop of 3.45" w.c., and cannot be used. Select a 2" RV-61 regulator gas train, which has a pressure drop of 1.19" w.c.

2. Prepare site • assemble burner • mount burner

Vent system

Vent/chimney sizing

1. Follow all local codes when sizing the vent and chimney.
2. Refer to the appliance manufacturer's manual, when available, for venting recommendations.

Prepare vent/chimney (Figure 1)

1. Secure all metal vent joints with screws, following the vent manufacturer's instructions. Seal all joints in the vent system and chimney. Repair masonry chimney lining and repair all mortar joints as needed.
2. Where draft fluctuations are likely, install a double-acting barometric draft regulator in the vent piping. (The damper must be located in the same space as the appliance.) Install a manual reset spill switch per manufacturer's instructions. Wire the switch into the appliance limit circuit to shut off the appliance/burner if sustained downdraft should occur. Refer to the appliance manufacturer's instruction manual for recommendations regarding the need for a barometric draft regulator.
3. Provide support for the vent piping. Do not rest the weight of any of the vent piping on the appliance flue outlet.

Inspect, repair and/or replace vent system

WARNING

Do not install this burner unless you have verified the entire vent system and the appliance are in good condition and comply with all applicable codes. And . . .

The vent and chimney must be sized and constructed in accordance with all applicable codes. If intended for use with an oil burner as well, the vent system must comply with relevant codes for both gas and oil firing.

The vent system must not be pressurized unless the vent piping and vent system are designed accordingly. The vent must provide draft at all times (negative pressure in vent).

Do not install or use an existing manual damper in the vent connector or vent.

Do not connect the appliance vent connector to a chimney or vent serving a fireplace, incinerator or solid-fuel-burning apparatus.

In a cold climate, do not vent into a masonry chimney that has one or more sides exposed to the outside. Install a listed stainless steel liner to vent the flue products.

A defective vent system could result in severe personal injury, death or substantial property damage.

Figure 1 Vent and vent connector installations, typical

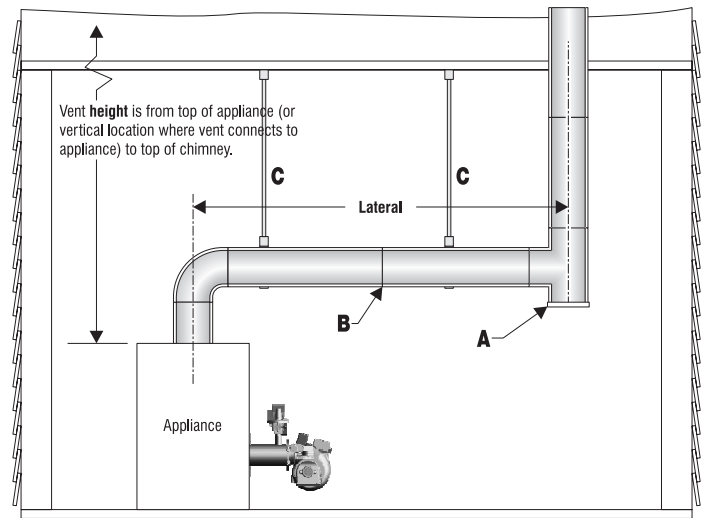

Metal vent application

- A** Connect to vertical with tee, if possible, to provide inspection/cleanout opening in vent.
- B** Seal all joints and access openings tightly to prevent draft loss.
- C** Support vent pipe so no weight of vent connector rests on appliance.

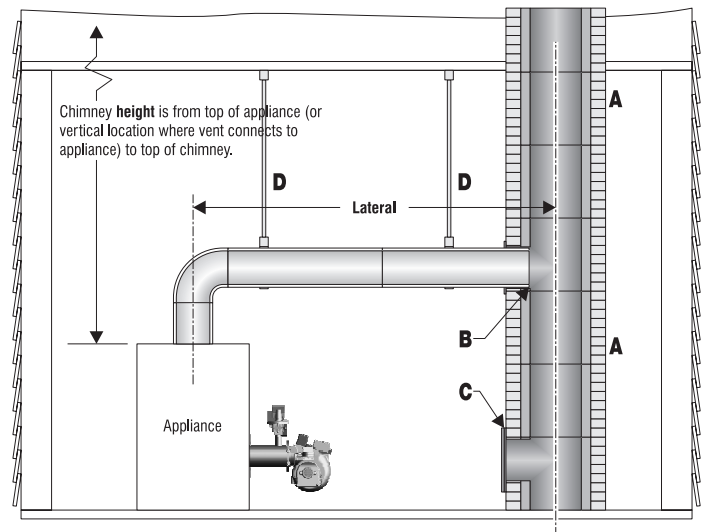

Masonry chimney application

- A** Tile-lined interior masonry chimney only; with all tile and joints in good condition.
- B** Vent pipe should be almost flush, but *not extending into*, inside surface of liner.
- C** Seal all access openings tightly to prevent draft loss.
- D** Support vent pipe so no weight of vent connector rests on appliance.

60102

Clearances

Check codes, standards and the equipment manual

- Verify that the burner/appliance will maintain all clearances to combustible walls or floor and all clearances required for service/maintenance as required in the appliance manual and applicable codes.

2. Prepare site • assemble burner • mount burner (continued)

Combustion air/ventilation openings

Sizing air openings

Follow all applicable codes and the appliance instruction manual (when available) to size combustion air openings. Use the following guidelines when appliance instructions are not available.

- All air from inside building (building must be well-ventilated):
Size air openings for a free area (after louver deduction) of at least 1 square inch per 1,000 Btuh input of all appliances in the space.
- All air through openings directly from outside the building through an adjacent outside wall:
If air openings connect directly to outside, provide two openings, one within 12 inches of the ceiling, the other within 12 inches of the floor. Each opening must have a free area (after louver deduction) of:
 - If directly through side wall: 1 square inch for each 4,000 Btuh of all appliances in the space.
 - If through vertical ducts: 1 square inch for each 4,000 Btuh of all appliances in the space.
 - If through horizontal ducts: 1 square inch for each 2,000 Btuh of all appliances in the space.

Locating air openings

Follow all applicable codes and the appliance instruction manual (when available) to size combustion air openings. Refer to Figure 2 when appliance instructions are not available.

Estimating free area

When specific information on the free area of louvers is not available, estimate free area as follows:

1. Wood louvers — free area = area times 0.25.
2. Metal louvers or grilles — free area = area times 0.60.
3. Screens, when used must be no smaller than ¼ inch mesh.

Motorized vent dampers

Wire the vent damper end switch to prevent operation of the burner until the air opening louvers are fully open.

Combustion air/ventilation opening checklist

- Verify that air openings are unobstructed.
- Verify that appliance space and air source spaces are free of:
 - Gasoline or other flammable liquids or vapors.
 - Combustible materials.
 - Air contaminants, such as laundry products, paint, thinner, varnish, etc.
- Confirm with user that the area will be kept free of these materials at all times.

WARNING

Installing the burner/appliance in a space that does not provide enough air for combustion and ventilation can result in severe personal injury, death or substantial property damage. Follow all applicable codes and guidelines below to ensure space has sufficient air openings.

WARNING

Exhaust fans and negative pressure conditions — Isolate the boiler room from areas subject to negative pressure. Size combustion air openings to ensure neutral air pressure in the boiler room whenever the burner operates.

WARNING

Make sure the space provides enough ventilation to prevent overheating of the appliance, burner and controls. If there is risk of overheating, you must install ventilation air openings sized large enough to provide air for cooling the equipment. Failure to provide ventilation can result in severe personal injury, death or substantial property damage.

WARNING

The space and combustion air supply must not contain corrosive contaminants, such as laundry products, paints, varnishes or other chemicals.

Figure 2 Locating combustion air/ventilation openings

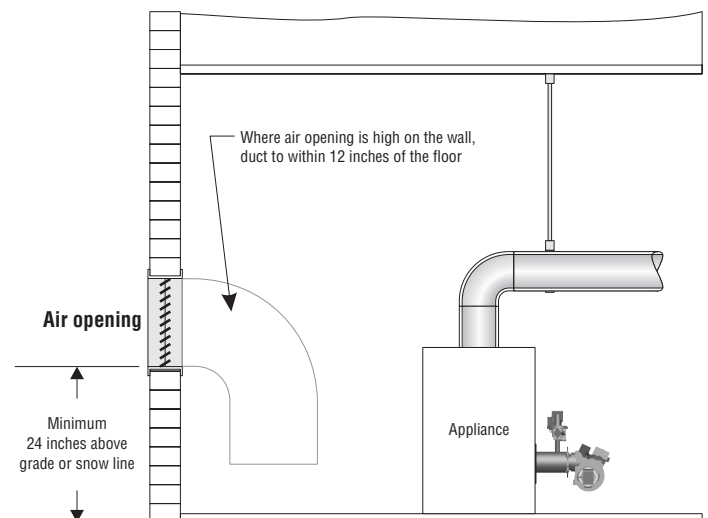

2. Prepare site • assemble burner • mount burner (continued)

Prepare the appliance

WARNING Burner input: Install a burner sized for the normal input rating of the appliance. Do not install a burner with a higher firing rate than the appliance rating. Do not install a burner with a firing rate more than 10% lower than the appliance rating. The appliance and vent system could be damaged due to condensation.

Clean the appliance: Clean the appliance thoroughly. Test all electrical components and verify the relief valve works (boilers only).

Seal the appliance: Seal all flue-gas containing joints. Seal all connections to the vent piping or breeching.

For applications not specifically tested for this burner. Verify combustion chamber dimensions comply with the minimum dimensions recommended on page 9. Install or replace chamber liner if required by the appliance manufacturer. The burner must not extend into the combustion chamber. The end of the burner air tube must be within ¼" of the inside face of the chamber. If the space around the burner air tube is more than ¼", wrap the burner air tube with minimum 2300-°F-rated ceramic fiber blanket to seal off the gap.

Repair or replace damaged appliance components. Inspect the appliance thoroughly. Follow appliance manufacturer's guidelines for repair or replacement of any component found defective.

When cleaning the appliance or working with ceramic fiber refractories or fiberglass insulation, see WARNING on this page.

Failure to comply with the above could result in severe personal injury, death or substantial property damage.

Overfire Pressure

WARNING Positive overfire pressure applications: When firing with positive overfire pressure, do not exceed the pressure specified in the appliance manual.

Positive overfire pressure reduces maximum burner capacity. See Page 4 for estimated reduction in burner capacity with pressurized firing and high altitude applications.

Failure to comply could result in severe personal injury, death or substantial property damage.

Prepare burner and components

WARNING Do not install or operate the burner if any component is damaged or if burner does not comply with the specifications of Table 2 and other guidelines in this manual.

Combustion chamber minimum dimensions

1. For applications that have not been specifically tested (OEM applications), verify that the combustion chamber provides the minimum dimensions
2. Chamber dimensions may be larger than listed in Table 2B, but should not be excessively large.

Ceramic fiber or Fiberglass insulation

WARNING Ceramic fiber materials, such as chamber liners, may contain carcinogenic particles (chrysothalites) after exposure to heat. Airborne particles from fiberglass or ceramic fiber components have been listed as potentially carcinogenic by the State of California. Take the following precautions when removing, replacing and handling these items.

Avoid breathing dust and avoid contact with skin or eyes. Wear long-sleeved, loose-fitting clothing, gloves and eye protection. Use a NIOSH N95 certified respirator. This respirator meets requirements for protection from chrysothalites. Actual job requirements or NIOSH regulations may require other or additional protection. For information, refer to the NIOSH website, <http://www.cdc.gov/niosh/homepage.html>.

Ceramic fiber removal: To prevent airborne dust, thoroughly wet ceramic fiber with water before handling. Place ceramic fiber materials in a plastic bag and seal to dispose.

Avoid blowing, tearing, sawing or spraying fiberglass or ceramic fiber materials. If such operations are necessary, wear extra protection to prevent breathing dust.

Wash work clothes separately from other laundry. Rinse clothes washer thoroughly afterwards to prevent contamination of other clothing.

NIOSH First aid procedures:

Eye exposure — irrigate immediately

Breathing — fresh air.

shown in Table 2A. For specific OEM applications, the appliance testing ensures suitability of the chamber.

2. Prepare site • assemble burner • mount burner (continued)

WARNING

Combustion chambers should be sized as recommended in Table 2A and 2B. They should be constructed of refractory materials with the capacity to withstand 2600°F or higher.

It is difficult to include all possible chamber constructions in this manual. Therefore, you should use the information presented in this manual combined with commonly practiced techniques when determining chamber design. If certain conditions are in question, consult the factory.

Using chamber linings

1. When using refractory liners or lightweight chambers, use insulating-type refractory rated 2600°F minimum, or as specified by the appliance manufacturer.
2. You must install a target wall liner if flame length is close to the length of the chamber.
3. Use a floor liner when possible. The floor liner will improve firing in most applications. Extend floor liner 3 to 4 inches up the side walls.
4. Target wall liners — Extend target wall liners at least 3 to 4 inches above the center of the flame corbel the top 1½ to 2½ inches deep.
5. Use preformed chamber liners when available. Lining the floor and target wall water-backed combustion chambers with lightweight insulating refractory will accomplish the same.
6. When converting coal-fired units, install a combustion chamber in the ashpit area, or fill the ashpit with sand up to 2 inches above the “mud ring” of the boiler (firing through the door). Install a lightweight refractory liner on the target wall.

Air tube insertion length (UTL)

1. Insertion air tube length (UTL) is the distance from mounting flange to end of air tube. Verify that the end of the air tube will be flush with, or no more than ¼ inch short of, the inside of the appliance combustion chamber front wall when the burner is mounted. See Figure 2A for further information.

NOTE: A spacer is available for an appliance with a UTL less than 4" (consult factory).

Figure 2A Chamber dimensions & tube configurations

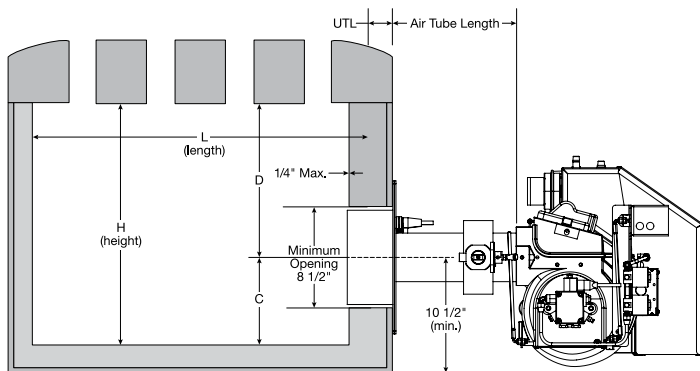

Table 2 Minimum combustion chamber dimensions (see Figure 3)

| TABLE 2A 801G/O MINIMUM DIMENSIONS RECOMMENDED IN REFRACTORY COMBUSTION CHAMBERS—(Inches) | | | | | |
|---|------------------|-----------------|-------------------|-------------------------------|--|
| 1 High Fire Oil Delivery Rate GPH @ 150 PSI | 2 Length L | 3 Width W | 4 Dimens. C | 5 Suggested Height H | 6 Minimum Dia. Vertical Cyl. |
| 11.4 | 33 | 15 | 7.5 | 15 | 31 |
| 12.0 | 34 | 16 | 8.0 | 16 | 32 |
| 12.6 | 35 | 16 | 8.0 | 16 | 33 |
| 13.2 | 36 | 17 | 8.5 | 17 | 34 |
| 13.2 | 38 | 17 | 8.5 | 17 | 36 |
| 14.4 | 39 | 18 | 9.0 | 18 | 37 |
| 15.0 | 40 | 18 | 9.0 | 18 | 38 |
| 15.6 | 41 | 19 | 9.5 | 19 | 39 |
| 16.2 | 43 | 19 | 9.5 | 19 | 41 |
| 16.8 | 44 | 20 | 10.0 | 20 | 42 |
| 17.4 | 46 | 20 | 10.0 | 20 | 44 |

| TABLE 2B 801G/O MINIMUM DIMENSIONS RECOMMENDED BOILERS FIRED WITHOUT COMBUSTION CHAMBERS—(Inches) | | | | | |
|---|--------------------------|-----------------------------|-----------------|-------------------|-------------------|
| 1 High Fire Oil Delivery Rate GPH @ 150 PSI | 2 L With Target | 3 L Without Target | 4 Width W | 5 Dimens. C | 6 Dimens. D |
| 11.4 | 33 | 38 | 17 | 7.5 | 9.5 |
| 12.0 | 34 | 39 | 18 | 8.0 | 10.0 |
| 12.6 | 35 | 40 | 18 | 8.0 | 10.0 |
| 13.2 | 36 | 41 | 19 | 8.5 | 10.5 |
| 13.8 | 38 | 43 | 19 | 8.5 | 10.5 |
| 14.4 | 39 | 44 | 20 | 9.0 | 11.0 |
| 15.0 | 40 | 46 | 20 | 9.0 | 11.0 |
| 15.6 | 41 | 47 | 21 | 9.5 | 11.5 |
| 16.2 | 43 | 49 | 21 | 9.5 | 11.5 |
| 16.8 | 44 | 50 | 22 | 10.0 | 12.0 |
| 17.4 | 46 | 52 | 22 | 10.0 | 12.0 |

2. Prepare site • assemble burner • mount burner (continued)

Inspect burner and components

- Check the air tube length. Verify the insertion length of the tube UTL will be long enough (see "Mount burner in appliance").
- Visually inspect all burner components and wiring.
- Verify that wiring is intact and leads are securely connected.
- Verify that all burner components are in good condition.

WARNING Do not install or operate the burner if any component is damaged or if burner does not comply with other guidelines of this manual and the appliance manual.

Mount burner in appliance

Welded-flange burners

1. Verify the bolt pattern on the appliance chamber matches the flange pattern.
2. Verify the insertion depth (UTL), including spacers, matches the depth of the appliance opening (so the end of the air tube is flush with, or slightly short of, the inside surface of the combustion chamber).
3. Place gasket onto boiler front plate.
4. Slide the end of the air tube into the opening and secure the flange to the boiler front plate.

Install the burner pedestal (optional)

1. Adjust the pedestal so that the height of the air tube matches the location of the burner opening.
2. The pedestal has approximately 3" of adjustment. If the burner opening is too high for the pedestal to rest on the floor, then construct a base. Two solid cement blocks, side by side, is recommended. Alternate the direction as layers are put down.
3. Place a spirit level on the air tube. Adjust the pedestal so the air tube slopes down slightly toward the appliance. The slope should be about 2 degrees.
4. Tighten the pedestal bolt securely.

Install the oil nozzles

1. Follow the instructions on page 27 to remove the combustion head assembly.
2. Install and tighten the nozzles listed in the appliance instruction manual or the Carlin OEM Spec Guide. If nozzle information is not available, begin with the nozzle listed on page 4. (You may have to change the nozzles later if combustion results are not acceptable.)
3. Hold the nozzle adapter securely when removing or replacing the nozzles. Take care not to damage the electrode insulators or to bend the electrodes in the process.

WARNING Inspect the nozzle adapter before replacing the nozzles. If the threads have been damaged or the adapter face shows score marks, replace the nozzle line/adapter assembly.

4. Check the electrodes and reposition if necessary. Position the electrodes as shown in Figure 3. These settings are critical in ensuring a reliable ignition.
5. Once the electrodes are set, check all clamps to be sure they are securely tightened.
6. Insert the combustion head/nozzle assembly into the burner and secure in place. See instructions on page 27.

Figure 3 Electrode settings

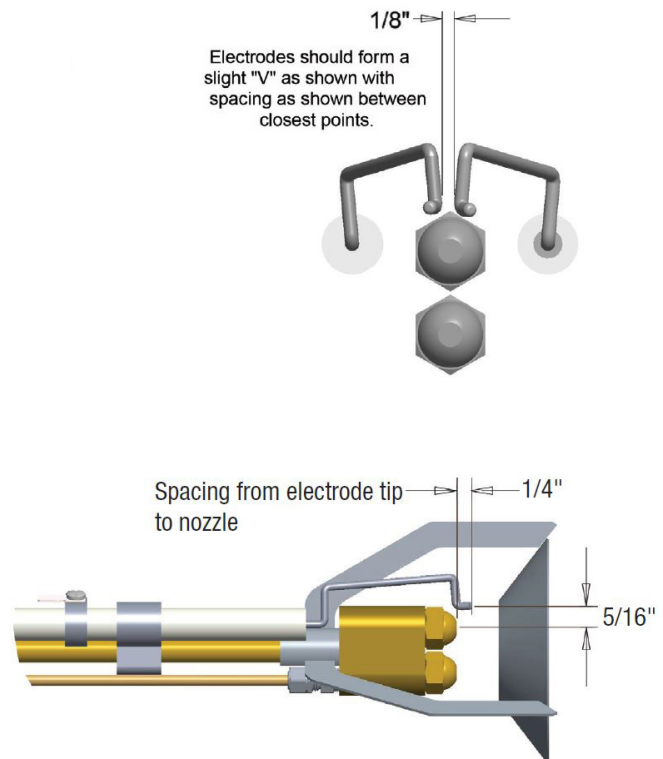

2. Prepare site • assemble burner • mount burner (continued)

Install gas train on burner

1. The standard burner gas train is shipped fully assembled, with the piping disconnected at the gas train unions. See separate instructions if installing an optional knocked down gas train. The gas train is available in either an angled (standard) or straight (optional) configuration.
2. Connect the main and pilot gas trains at the unions (Figure 4).

WARNING To avoid damage to gas train components, do not hold components with a pipe wrench or overtighten. Use only a crescent wrench or other means. Failure to comply could result in severe personal injury, death or substantial property damage.

3. Connect the flexible conduit, pre-attached to the burner J-box, to the gas train J-box, and attach the wires to the terminal strip inside the gas train J-box.
 - a. Match wire colors of the incoming wires to those pre-wired to the terminal strip inside the gas train J-box.
 - b. See the label in the burner junction box or the wiring diagram on page 16.

NOTICE Gas valve vent opening — The V48 diaphragm gas valve is NOT fitted with a vent limiting orifice in the vent connection. If local codes require, install piping from the vent connection to outside, sized and installed as required by codes. Because this is a diaphragm-assisted solenoid valve, a small amount of gas will exit from the vent orifice each time the valve opens.

Figure 4 Gas train installation

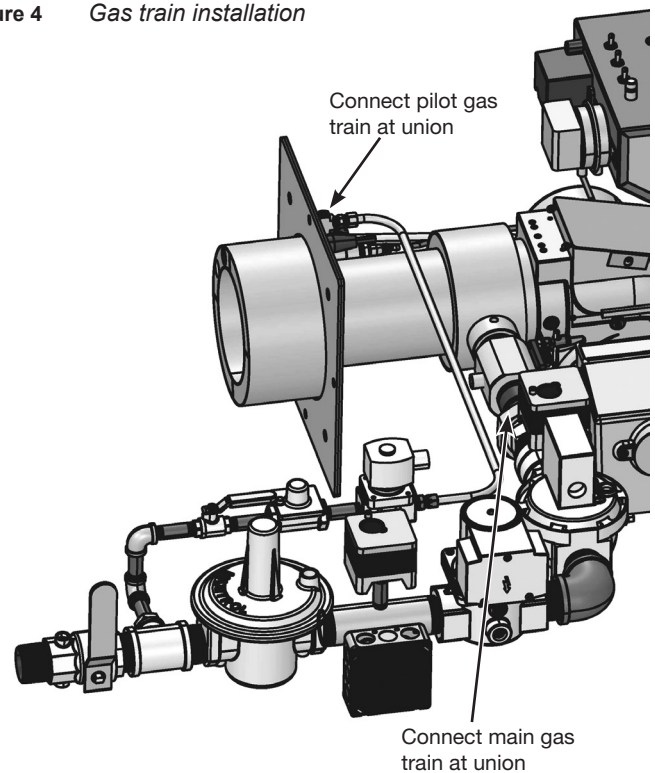

Inspect components and wiring

- Visually inspect all burner components and wiring.
- Verify that wiring is intact and leads are securely connected.
- Verify that all burner components are in good condition.

Figure 4A Gas Piping Schematic

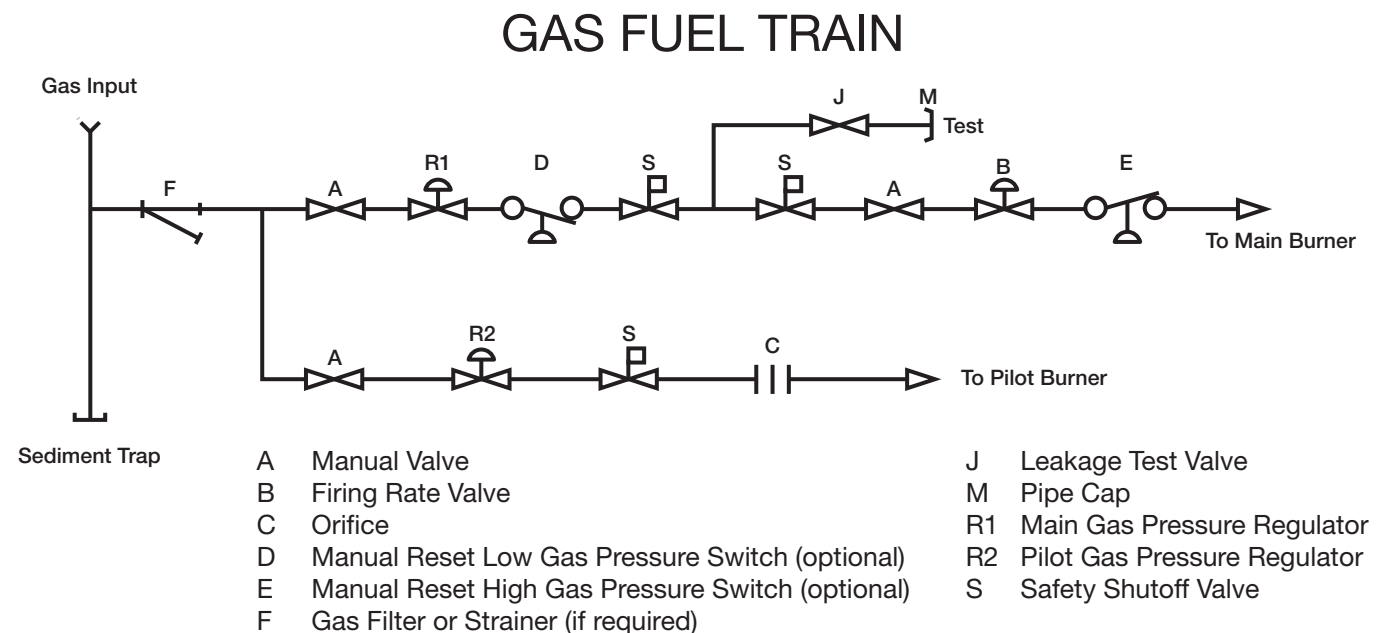

3. Install gas piping

WARNING Connect from the gas supply to the burner gas train inlet using new, clean black iron pipe and malleable iron fittings. Do not use copper, brass, cast iron or galvanized pipe or fittings.

Provide support for gas piping. Do not rest the weight of the gas piping on burner gas train.

Provide a support for the burner gas train.

Apply pipe dope sparingly at all joints. Use only pipe dope listed for use with propane gas. Do not use pipe sealing tape.

Do not hold the gas valve with pipe wrench. Use crescent wrench or other smooth-jawed device. Do not overtighten.

Failure to comply with above could result in severe personal injury, death or substantial property damage.

WARNING Do not expose the gas train to gas pressure in excess of 14 inches water column. Higher pressure could damage the valve seat, resulting in potentially hazardous condition. When pressure testing piping at higher pressures, disconnect burner from gas line before testing.

If the gas supply pressure can exceed 14 inches water column at any time, you must install a lockup type gas pressure regulator in the gas supply piping, ahead of the main manual gas valve installed at the burner.

Piping from gas meter to burner

1. Verify the gas train on the burner is correctly sized. The gas train pressure drop must not be more than the gas pressure at the burner gas train entrance minus 3.4" w.c. (pressure required at entrance to butterfly valve). See Figure 6 for gas train pressure drop information. The standard gas train is 1½ inch.
2. If possible, install a new gas line directly from the gas meter. If you are using an existing gas line, verify it is clean and in good condition, and verify it is large enough to handle the load of all connected appliances.
3. When branching from a common gas line, do not tap off from the bottom of horizontal sections — only from the side or top.
4. Install a main manual shutoff valve, sediment trap and ground joint union near the burner gas train connection as shown in Figure 5.
5. If the burner is installed inside an appliance jacket, install the main manual gas valve and sediment trap external to the jacket.
6. Size piping (or verify size) using page 13. You will find additional information on gas line sizing in the National Fuel Gas Code, ANSI Z223.1.
7. Gas supply pressure — natural gas or propane
 - Maximum supply pressure: 14 inches w.c.
 - Minimum supply pressure: 5 inches w.c.

Test and purge gas line

Read WARNING above.

Pressure test and purge the line. Pressure testing should be done by the gas supplier or utility, following all applicable codes.

Figure 5 Connecting gas supply piping to burner

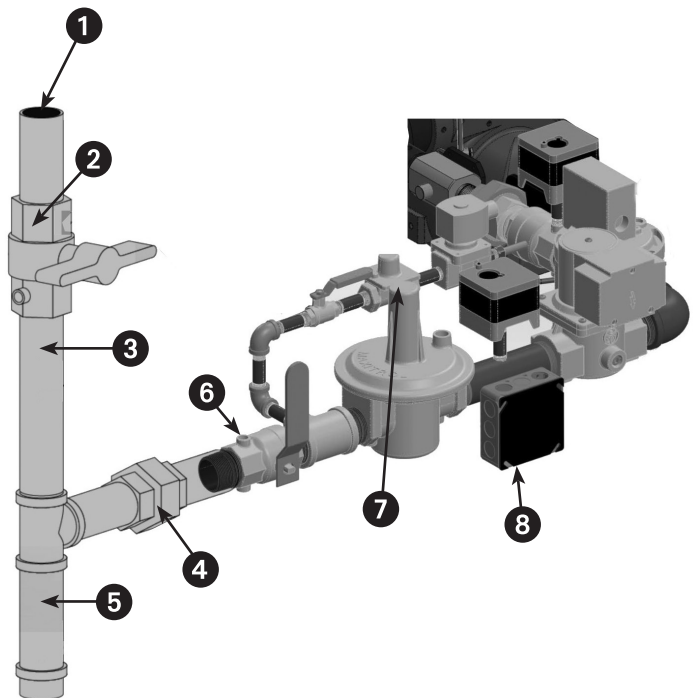

- | | | | |
|---|--|---|--|
| 1 | Pipe to meter or branch | 6 | Pressure tap, 1/4" (upstream shown, outlet not shown) |
| 2 | T-handle main manual gas valve | 7 | Gas regulator access screw (the regulator spring is located under the adjusting screw) |
| 3 | Use clean, burr-free black iron pipe and malleable iron fittings | 8 | Gas train wire junction box |
| 4 | Ground joint union | | |
| 5 | Sediment leg | | |

3. Install gas piping (continued)

Table 3 Capacities of black iron pipe, cubic feet gas/hour

| NATURAL GAS Capacities in Cubic feet per hour for Schedule 40 metal pipe | | | | | |
|--|--|-------|-------|-------|-------|
| Pipe size (inches) | Total length of gas piping, from meter to burner connection (feet) | | | | |
| | 20 | 40 | 60 | 80 | 100 |
| Natural gas @ .60 specific gravity, pressure drop 0.3 in. w.c. (note 1) | | | | | |
| 1¼ | 730 | 500 | 400 | 350 | 305 |
| 1½ | 1,100 | 760 | 610 | 530 | 460 |
| 2 | 2,100 | 1,450 | 1,150 | 990 | 870 |
| 2½ | 3,300 | 2,300 | 1,850 | 1,600 | 1,400 |
| Natural gas @ .60 specific gravity, pressure drop 0.5 in. w.c. (note 1) | | | | | |
| 1¼ | 950 | 660 | 530 | 460 | 400 |
| 1½ | 1,460 | 990 | 810 | 690 | 620 |
| 2 | 2,750 | 1,900 | 1,520 | 1,300 | 1,150 |
| 2½ | 4,350 | 3,000 | 2,400 | 2,050 | 1,850 |
| Note 1 | For natural gas with specific gravity other than 0.60, consult National Fuel Gas Code for correction factor. | | | | |

| PROPANE GAS Capacities in Btuh for Schedule 40 metal pipe | | | | | |
|---|-------|-------|-------|-------|-------|
| Propane gas @ 1.5 specific gravity, pressure drop 1 psi | | | | | |
| ½ | 1,839 | 1,264 | 1,015 | 869 | 770 |
| ¾ | 3,845 | 2,643 | 2,122 | 1,816 | 1,610 |
| 1 | 7,243 | 4,978 | 3,998 | 3,422 | 3,033 |
| Propane gas @ 1.5 specific gravity, pressure drop 0.5 in. w.c. | | | | | |
| 1 | 787 | 541 | 434 | 372 | 330 |
| 1¼ | 1,616 | 1,111 | 892 | 677 | 543 |
| 1½ | 2,422 | 1,664 | 1,337 | 1,114 | 1,014 |

Figure 6 Gas train pressure drop

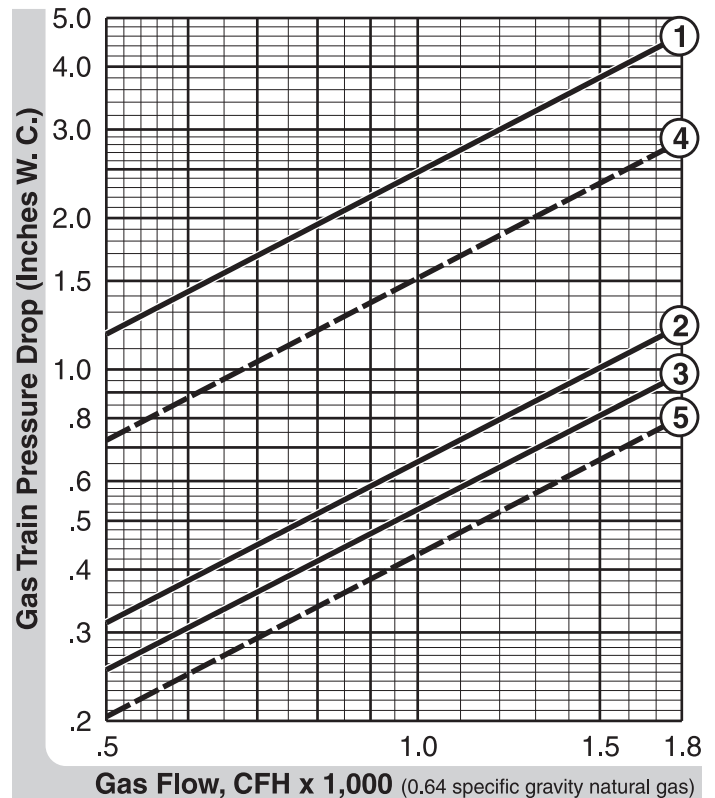

- ① 1" Standard gas train with RV61 regulator
- ② 1¼" Optional gas train with RV81 regulator
- ③ 1½" Optional gas train with RV81 regulator
- ④ PROPANE: 1" Standard gas train with RV61
(Propane flow is NOT in CFH. Flow is in millions of Btu's/hr.)
- ⑤ PROPANE: 1¼" Optional gas train with RV81
(Propane flow is NOT in CFH. Flow is in millions of Btu's/hr.)

NOTICE Regulator spring:
The standard main gas pressure regulator spring 1½" RV81 is plated. The range is from 3.0 to 6.0 inches water column (or a violet spring, with a range of 4.0 to 12.0 inches water column).

4. Install oil piping

Use two-line oil piping only

WARNING Use two-line oil piping only

Fuel unit bypass plug

WARNING The fuel unit is shipped with its bypass plug installed. Operating with the plug in place on a one-line system (not recommended) will damage the fuel unit and could lead to oil leakage and fire hazard.

WARNING If the fuel line or fuel supply is above the burner, never exceed 3 PSIG pressure at the fuel unit inlet. Install a suitable OSV to reduce the pressure. Operating the fuel unit with higher inlet pressure could result in fuel unit seal damage, oil leakage and potential fire hazard.

Guidelines:

- When installing oil lines, use continuous runs of heavy-wall copper tubing on properly sized black piping.
- Check fuel unit (oil pump) data sheet for recommended line sizing, lift limitations and maximum length.
- Check all connections and joints to ensure they are air-tight.
- Use flare fittings. DO NOT use compression fittings.
- Never use pipe sealing tape. Fragments can break off and plug fuel line components.
- Install a shut-off valve at the tank and one near the burner. (Use fusible handle design valves when possible or when required by codes.)
- Install a large capacity fuel filter (rated for 50 microns or less) near the burner.

Inspect/install fuel supply

CAUTION Inspect the oil supply system. Ensure that the fuel lines are correctly sized and installed and that the fuel flow is unobstructed, the oil tank is clean and only # 1 or # 2 heating oil are supplied. Failure to supply a reliable oil flow could result in loss of heat and potential severe equipment damage.

1. See Figure 7 for typical two-line oil piping.
2. See page 16, Figures 8 and 9, for fuel unit oil flow diagrams.
3. Install the fuel unit bypass plug (two-line systems only).

Fuel supply to multiple burners

- When possible, use separate fuel supply lines for each oil burner. Using manifolded oil supply lines can create problems. If the lines are undersized, operating vacuum will exceed limits. If the lines are oversized, fuel units may have difficulty priming. Because the lines must be sized to handle the capacity of all the burners, the line size will almost always be too large when only a single burner is running.
- If manifolding cannot be avoided, carefully size the lines following the fuel units manufacturer's instructions.

Fuel unit vacuum limitations

- See Table 4 for allowable lifts and lengths of oil lines.
- The vacuum at the fuel unit inlet port must not exceed 12 inches mercury during any operating condition.
- Attach a vacuum gauge to either of the fuel unit inlet ports, and verify the vacuum does not exceed the limit below during all firing conditions.

Oil flow schematic / fuel unit connections

- Figure 8 shows oil flow and fuel unit port functions for Carlin 801G/O burners.
- Figure 9 applies only for optional NYC-DAR pressure regulation kits.

NOTICE The National Oilheat Research Alliance (NORA) recommends single pipe oil systems and high-quality filtration for all fuel types. This should include at least a 10 micron Spin-on filter. Double filtration provides even greater assurance clean fuel will get to the pump. Contaminants in the tank that enter the fuel supply to the burner can cause pump sticking/seizing. These contaminants may increase in the early stages of transitioning to modern fuels (Ultra Low Sulfur and Bio Blends). High quality filtration adds protection against pump sticking.

4. Install oil piping (continued)

Figure 7 Two-line fuel system

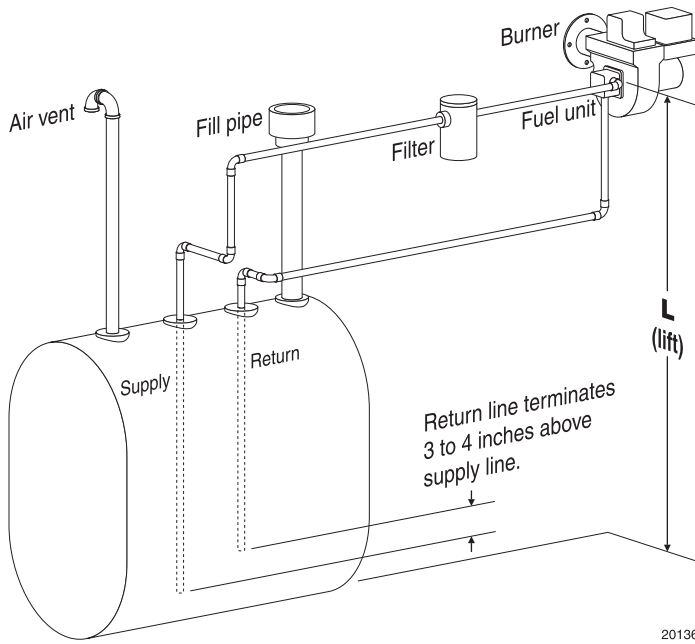

Figure 8 801G/O fuel unit and flow diagram

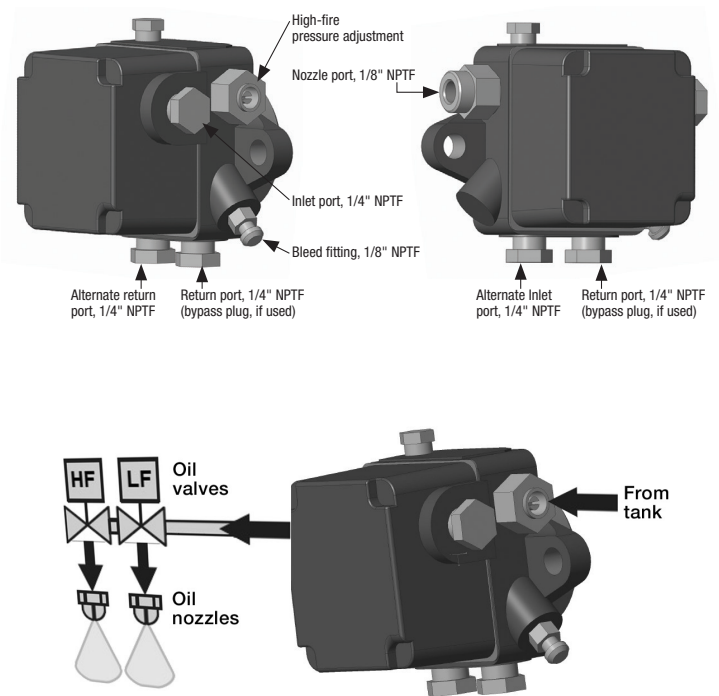
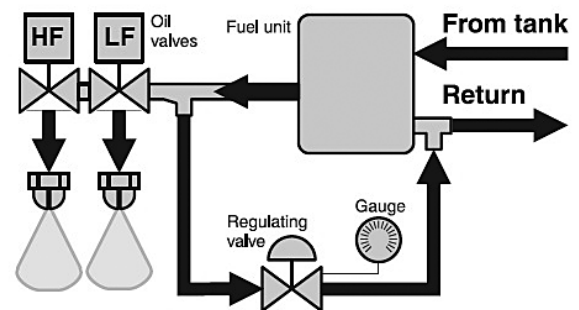

Table 4 Two-line fuel system - allowable lengths and lifts

| Lift (feet) | Length of tubing (feet) | |
|-------------|-------------------------|-----------|
| | 3/8" O.D. | 1/2" O.D. |
| 0 | 41 | 100 |
| 2 | 37 | 100 |
| 4 | 32 | 100 |
| 6 | 28 | 100 |
| 8 | 24 | 96 |
| 10 | 20 | 80 |
| 12 | 16 | 64 |
| 14 | — | 48 |
| 16 | — | 32 |

Figure 9 801G/O burner with NYC-DAR pressure regulation kit

NOTICE Obtain pressure regulator kits for New York City Department of Air Resources from Carlin. Kits must be set for the proper nozzle pressure.



5. Wire the burner — RM7897C primary control

WARNING Turn off power to appliance when servicing burner. Failure to comply could result in severe personal injury, death or substantial property damage.

NOTICE A jumper is present in terminal 12 and 13. This should be removed to install a low/ high fire controller, or if you are using pressure switches (see next page).

NOTICE If the burner is equipped for use with an Outside Temperature Switch, please reference included supplement MNAFCO.

Wire the burner (RM7897C primary control only)

1. All wiring must comply with:
 - In the U.S. — the National Electrical Code, ANSI Z223.1/NFPA 54.
 - In Canada — the Canadian Electrical Code Part 1, CSA standard C22.1.
 - All applicable local codes/standards.
2. Connect the burner following Figures 11 and any special instructions or wiring diagrams provided with the appliance, burner or other components.
3. The burner requires a 120 VAC/60 hz/single-phase control power supply, with a 10-amp fuse. The control circuit current draw is approximately 1.2 amps. An additional power source is required for the motor (120 VAC or 208-220 VAC, 60 hz), with fuse sized accordingly.
4. Read the Honeywell RM7897C instructions for information on setting a room thermostat, if used.
5. Make sure the burner and appliance are correctly wired and the line switch is properly fused for the load.

Low-High-Low step modulation

1. To take advantage of the energy-saving potential of the Model 801G/O combination gas/oil burner, it should be wired to operate at low-high-low cycles. The firing cycle can be much longer using low-high-low firing, because the burner can cycle to low fire as demand decreases. This keeps the burner on longer, reducing cyclic losses.
2. The appliance must be equipped with a high fire control. This would be a break on rise control, either temperature (water boiler) or pressure (steam boiler) activated. Read the appliance manual for the location of the high fire control, when used.
3. See Figure 11 to connect the high fire control to the burner firing rate circuit.
4. The burner includes a pre-wired Low Fire Hold Switch. Close this switch to run the burner in high fire. Open the switch to run the burner in low fire.

5. Wire the burner — RM7897C primary control (continued)

Figure 11
801G/O burner wiring
using Honeywell
RM7897C primary
control (see appliance
manual or separate wiring
information for burner
equipped with a primary
control not covered in this
manual); see Figure 10 for
a legend to callouts

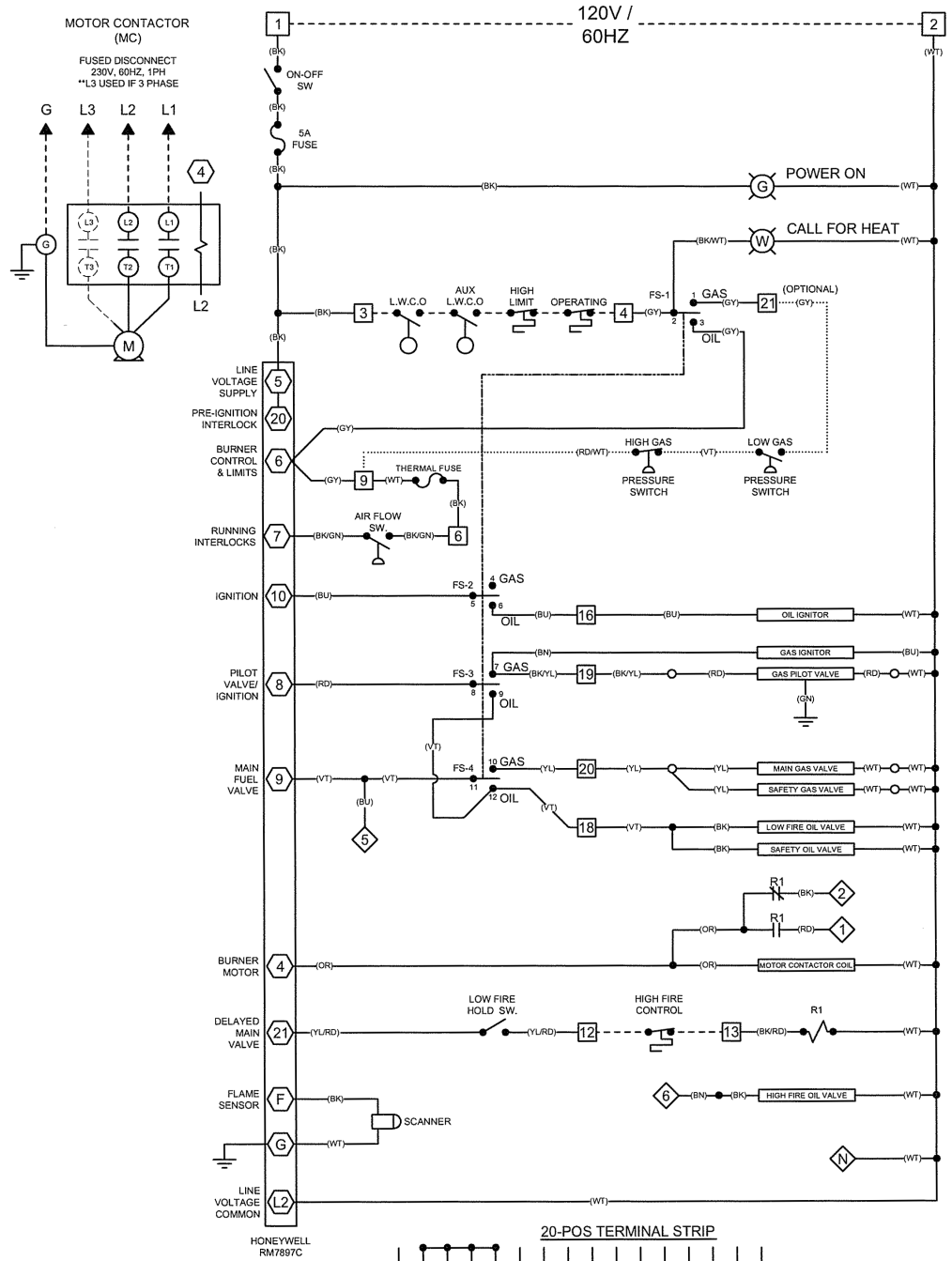

Figure 10 Legend for Figure 11

| |
|--------------------------------|
| LEGEND |
| — FACTORY WIRING |
| - - - FIELD WIRING |
| () WIRE COLOR |
| R1 HIGH FIRE RELAY |
| ⬡ HONEYWELL TERMINALS |
| □ CONTROL CABINET TEMPERATURE |
| ◇ SQN7 DAMPER MOTOR CONNECTORS |
| ○ J-BOX TERMINALS |
| ● WIRE NUT/CRIMP CONNECTOR |
| COLOR CODES |
| BK - BLACK GN - GREEN |
| WT - WHITE OR - ORANGE |
| BU - BLUE RD - RED |
| BN - BROWN VT - VIOLET |
| YL - YELLOW GY - GRAY |

6. Checkout procedure — before starting the burner

Before firing the burner . . .

WARNING

Should overheating or an emergency occur, immediately do the following:

- Shut off oil supply line and gas supply valves.
- Under some circumstances power should remain on for water pumps or blowers. Determine proper response before attempting start-up.
- If burner fails ignition on several attempts, use burner blower to purge appliance chamber before restart.

Checklist before firing . . .

- Burner and appliance installed per this manual and appliance instruction manual?
- Burner/appliance installed per all applicable codes?
- Installation site has adequate combustion/ventilation air openings and vent system?
- Are voltages correct? Burner, appliance and motor correctly wired per burner and appliance manuals and wiring diagrams?
- Gas manifold spud orifices sealed with pipe dope and tight?
- Burner nozzle verified per appliance manufacturer's instructions, Carlin OEM Spec Guide or Table 1, page 5?
- Gas and oil supply lines in good condition, sized and designed correctly?
- Gas and oil line connections and fittings tight?
- Oil tank has oil, and oil line valves are open. Oil supply and return lines purged?
- Burner, appliance and all components inspected and in good condition?
- Appliance limit and operating controls properly installed, wired and adjusted?
- Boiler water supply, feed pumps, automatic feeders, and low water cut-offs properly piped and wired?
- Breeching, draft regulator, draft inducer (if required) properly installed and operational?
- Gas train piping and components correctly installed, tested and verified gas tight?
- Vent lines installed when required?
- Gas lines purged?
- Sufficient gas line pressure present?

7. Set burner initial head and damper positions

WARNING

Follow the procedures given here and on the following pages to ensure the burner is correctly adjusted. Take your time and the results in both gas and oil modes should result in good operation, and avoid return service calls.

You must perform the adjustments in the sequence given in this manual.

Failure to follow the correct procedures could result in severe personal injury, death or substantial property damage.

Before firing the burner . . .

Set combustion head (Dimension "A")

1. The combustion head adjusting screw is used to set the spacing between the retention ring and throttle ring (or air cone), regulating how much air passes around the retention ring.
2. See Figure 12. Loosen the two housing cover screws. Then rotate the head adjusting screw until the distance from the housing detent to the beginning of the scale or scribed line on combustion head equals the value given in Table 5 (Dimension "A"). Tighten the housing cover screws.

Set air damper (low fire position)

1. See Figure 13. Loosen the air damper adjusting screw and locknut. Rotate the adjusting screw until the air opening between the damper and the damper housing equals the initial low-fire opening in Table 5. Leave screw and locknut loose until final adjustment.

7. Set burner initial head and damper positions (continued)

Set the air damper linkage

1. Make sure Air Damper Linkage is set at 1/2" from the top of the Damper Motor and the center of the linkage screw (see figure 14). If your settings are off, loosen the two hex head screws found on the linkage arm bosses at the top and bottom of the Air Damper Linkage (see figure 13 for bottom example). Adjust the linkage accordingly, then tighten screws to set position.

Determining final adjustments

1. The burner is now adjusted to the **approximate** air settings for the firing rate used. Follow the procedures on the following pages to **use test instruments** and make final burner adjustments.

Figure 12 Set initial combustion head position

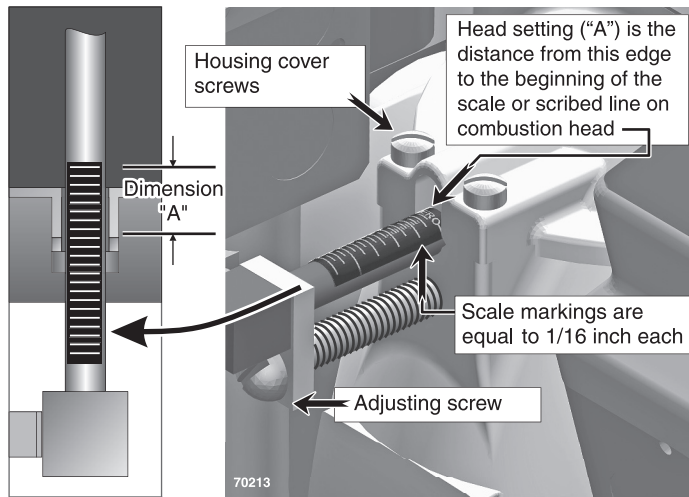

Figure 13 Set initial low fire air damper setting

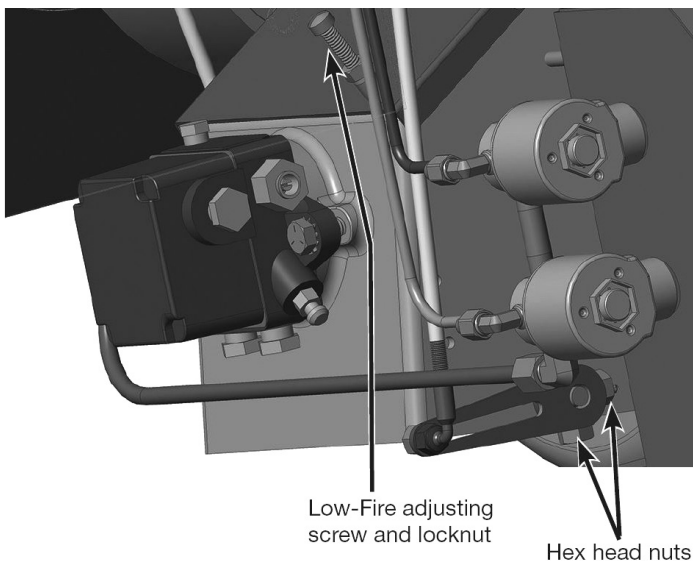

Table 5 Initial burner settings (see pages 22 through 26 for final adjustments using test instruments)

Air Settings below are for combustion chambers with neutral over-fire pressure. Adjustments will need to be made for appliances with pressurized chambers.

| TABLE 5 801G/O NOZZLE DATA AND COMBUSTION HEAD SETTINGS | | | | | | | |
|--|-----------|------------------------------------|-----------|----------|-----------|---|----------------------------|
| Nozzle Specifications Hago Products Corp. | | Oil Delivery Rate GPH @ 150 PSI | | Gas MBH | | "A" Approximate Retention Ring Setting On Scale | Low Fire Air Shutter |
| 1st Stage | 2nd Stage | Low Fire | High Fire | Low Fire | High Fire | | |
| 5.50 | 3.00 | 6.60 | 10.40 | 924 | 1457 | 1/16" | 0 |
| 5.50 | 4.00 | 6.60 | 11.40 | 924 | 1597 | 1/16" | 1/4" |
| 5.50 | 4.50 | 6.60 | 12.00 | 924 | 1681 | 1/16" | 1/4" |
| 5.50 | 5.00 | 6.60 | 12.60 | 924 | 1765 | 1/48" | 1/4" |
| 5.50 | 5.50 | 6.60 | 13.20 | 924 | 1849 | 3/16" | 1/4" |
| 6.00 | 5.50 | 7.20 | 13.80 | 1008 | 1933 | 1/4" | 3/8" |
| 6.00 | 6.00 | 7.20 | 14.40 | 1008 | 2017 | 5/16" | 3/8" |
| 6.00 | 6.50 | 7.20 | 15.00 | 1008 | 2101 | 3/8" | 3/8" |
| 6.50 | 6.50 | 7.80 | 15.60 | 1092 | 2185 | 7/16" | 1/2" |
| 6.50 | 7.00 | 7.80 | 16.20 | 1092 | 2269 | 1/2" | 1/2" |
| 6.50 | 7.50 | 7.80 | 16.80 | 1092 | 2353 | 3/8" | 1/2" |
| 6.50 | 8.00 | 7.80 | 17.40 | 1092 | 2437 | 3/4" | 1/2" |

Nozzle Specs. – Preferred: Hago 45°H
Alt.: Delavan 45B or 45A

Figure 14 Setting air damper linkage

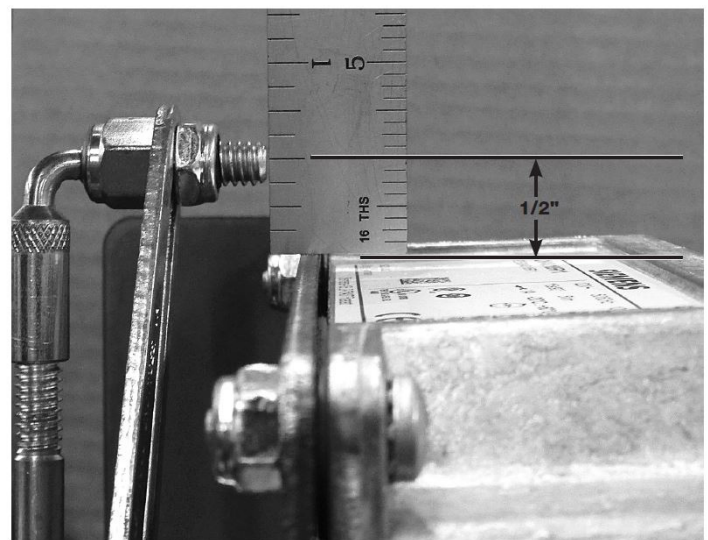

8. Adjust the burner using test instruments

WARNING The settings given in Section 7 are initial settings only. **You must use test instruments** to check combustion, and adjust the burner as necessary, following the procedures given in the following pages of this manual. Failure to properly adjust the burner can result in severe personal injury, death or substantial property damage.

NOTICE When possible, refer to the Carlin OEM Guide for 801G/O appliance specific nozzle sizes and air settings.

Adjustment procedure, summary

- Step 1:** Set high-fire oil airflow by adjusting the combustion head. See details following.
- Step 2:** Adjust the air damper for low-fire oil. See details following.
- Step 3:** Adjust the damper motor end switch (only if necessary). See details following.
- Step 4:** Set gas pilot operation. See details following.
- Step 5:** Set high-fire gas flow to match high-fire air. See details following.
- Step 6:** Adjust the butterfly valve linkage to match low-fire gas to low-fire air. See details following.
- Step 7:** Verify operation of burner, appliance, and controls.

Use test instruments

1. Use combustion test equipment and an accurate manometer or draft gauge to correctly set the burner as required.
2. Overfire pressure must not exceed the appliance manufacturer's recommendations. The burner must never be fired at an overfire pressure more than 0.60 inches w.c.

NOTICE When the overfire pressure is positive, the maximum burner firing rate is reduced. The firing rate is also reduced for altitudes higher than 2000 feet above sea level. See page 4 for rating information. Ensure that the oil nozzle selected is correct the required firing rate.

3. Adjust the burner fuel and air settings using the following procedures. When adjustment has been completed, the CO₂ (or O₂) should be within the ranges in Table 6, at both low fire and high fire.

Table 6 Allowable values of CO₂ and O₂

| Fuel | CO ₂ | | O ₂ | |
|-------------|-----------------|---------|----------------|---------|
| | Minimum | Maximum | Maximum | Minimum |
| #2 Fuel Oil | 10.5 % | 12.5 % | 6.6 % | 3.9 % |
| Natural Gas | 8.5 % | 10.0 % | 6.2 % | 3.6 % |
| Propane | 9.5 % | 11.2 % | 6.0 % | 3.5 % |

Start the burner (firing on oil)

WARNING Do not start the burner if the combustion chamber contains oil or oil vapor.

NOTICE When the burner is equipped for use with an Outside Temperature Switch (not supplied by Carlin), this switch will supply either a 120Vac OIL signal or a 120Vac GAS signal to the burner control panel's OIL/GAS circuit. When set to AUTO, the burner will run on the fuel selected by the Outside Temperature Switch.

1. Turn service switch OFF.
2. Perform inspections and checkouts on page 20.
3. Verify burner is set according to page 20.
4. Slip one end of a 3/16-inch I.D. clear plastic hose over the end of the fuel unit bleed valve, the other end into a container. Then open bleed valve.
5. Set burner fuel selector switch to OIL.
6. Set thermostat (operating controls) to call for heat.
7. Turn service switch ON.
8. Burner motor, fuel unit and blower should turn on.
9. Bleed the oil line until the plastic line is free of bubbles; then another 15 seconds longer. (Should the primary control timing cause a lockout during purging, restart the burner following the primary control data sheet instructions.)
10. Close the bleed valve. The burner should cycle through the sequence given in the primary control data sheet.
11. Should control/burner fail to operate correctly, shut burner off immediately and check burner settings and fuel supplies.
12. Operate burner for 15 minutes before making final adjustments using test equipment.
13. Check for leaks in fuel piping.

WARNING Inspect fuel piping system for leaks. Repair any leaks to avoid fire hazard from oil leakage or combustion problems due to air infiltration into oil.

14. Inspect the flame
 - Look at the flame through the appliance combustion chamber observation port, if available. The flame should be well-defined and should not impinge on any appliance surface. (If you make air changes later, inspect the flame again.)

WARNING **Do not attempt to confirm combustion simply by inspecting the flame visually. You must use combustion test instruments.** Failure to properly verify/adjust combustion could allow unsafe operation of the burner, resulting in severe personal injury, death or substantial property damage.

15. Insert the combustion equipment test probe into a vent sample opening to sample flue products.

WARNING All installations should be checked after one to two weeks of operation to ensure the appliance/burner units are operating correctly.

8. Adjust the burner using test instruments (continued)

NOTICE

The linkage between the damper motor arm and the air damper crank is set at the factory, and should ONLY need adjustment if the damper motor or the damper rod is replaced. With the burner in high-fire position, there should be minimal play in the connecting rod. DO NOT change this linkage setting.

Step 1 (firing on oil)

Set combustion head (Dimension "A")

1. Allow the burner to operate approximately 15 minutes to ensure the appliance is heated and combustion is steady.
2. Set the draft as specified in the appliance manual.
3. The combustion head adjusting screw is used to set the spacing between the retention ring and throttle ring, regulating how much air passes around the retention ring. (See Figure 12, page 19.) The larger the value of dimension A, the larger the clearance, so the larger the airflow. The smaller the value of dimension A, the smaller the airflow.
4. Measure the %CO₂ in the appliance flue. The value should be approximately 12.5% for high fire oil. If the CO₂ is higher than 12.5%, adjust the head adjusting screw (see Figure 12, page 19) to a larger dimension A to increase airflow. If the CO₂ is less than 12.5%, adjust the screw to a smaller dimension A to decrease airflow.
5. Reset draft as specified in the appliance manual, after any airflow adjustment.
6. Check the smoke value in the appliance flue. It must be zero to a trace. If not, try increasing airflow (reducing the CO₂). If increasing airflow increases smoke, the combustion is probably on the wrong side of the CO₂ curve. To correct, increase the airflow until the smoke is eliminated.
7. When adjustments are completed, the CO₂ must be between 12.0% and 12.5% at high fire oil, with smoke equal to zero or a trace. High fire draft should be set to -02 to +.060 ofd as per boiler manufacturer specifications, this can be accomplished by adjusting the manual damper on the exhaust outlet of the appliance. Whenever possible please see OEM appliance boiler manual for Carlin 801G/O specifications or for recommended firebox draft settings.

Step 2 (firing on oil)

Set low-fire damper

1. Flip the low-fire switch to low fire.
2. The burner will supply oil only to the low fire nozzle.

3. See Figure 14, page 21. Adjust the blue cam until the low-fire CO₂ is between 11% and 12%. Adjust the cam clockwise to increase airflow (reduced CO₂). Adjust the cam counterclockwise to decrease airflow (increase CO₂).
4. Smoke at low fire must be zero or a trace. Note that too much air can actually increase smoke.

Step 3 (firing on oil)

Damper actuator end switch position

See included supplement MNSQN71 (pg.32) for visual callouts and instructions on setting Damper Actuator.

1. Modulate the burner from low fire to high fire and back to low fire, pausing at each step for about one minute.
2. If the swing from low fire to high fire is rough (burner bangs or rumbles), or the fire is very smoky, the damper end switch may be in the wrong position. High-fire oil should pull in as the air damper is about halfway through its swing.
3. For different appliance applications, it is sometimes necessary to have high-fire oil earlier or later than normal during the swing to achieve a smoother, cleaner transition.
4. If the swing is rough (flame goes out, bangs or rumbles), there could be air in the oil, or the nozzle may be defective. Check, and replace the nozzle if necessary. Then retry.
5. If the fire is too lean, the flame could lift off of the head, causing rumble or unsteady combustion. In this case, adjust the modulating motor to energize **earlier**.
6. If the flame is very smokey, adjustment to the switching points may need to be made.
 - Adjustments of the switching points are done by means of adjustable cams
 - Scales beside the cams indicate the angle of the switching point
 - Assignment of cams to the end of auxiliary switches is color-coded
 - Some of the cam feature fine adjustment they can be adjusted with a standard screwdriver
 - The other cams can be adjusted manually or with a hook-spanner or similar tool
7. Restart the burner and check modulation again. Continue with 1 through 6 above as needed until results are acceptable.
8. Turn off the burner when Step 3 is completed before proceeding with setup for gas combustion, Step 4.

8. Adjust the burner using test instruments (continued)

WARNING Smell around the gas train and check all joints with a soap suds mixture to ensure the gas train and all components are tight and leak-free. Shut down the burner and correct any leak immediately. Failure to comply could result in severe personal injury, death or substantial property damage.

Step 4 (firing on gas) Check gas pilot operation

NOTICE The Model 801G//O uses a gas pilot for ignition of the gas main flame. The gas pilot is ignited by the pilot electrode.

1. After completing Steps 1, 2 and 3 on page 21, move the burner fuel selector switch to GAS. Set the low-fire switch to low fire.
2. Make sure the gas line has been completely bled. Then turn the service switch to ON.
3. The pilot will usually light the first time once the pilot gas train has been completely purged of air.
4. The pilot flame is approximately 75 MBH, and is large enough to be heard when lit. If the pilot fails to light, be sure the gas line has been bled properly. If it still fails to light, increase the pilot gas pressure to 4 inches w.c. If the primary control is equipped with a pilot test hold switch, it can be used to hold the pilot "on" while adjusting pilot gas pressure.
5. Follow the instructions in the primary control instruction manual to check flame signal. Make sure the flame signal is steady, and greater than the required minimum for the UV sensor.
6. Check and ensure that the bent ignitor (Figure 15 is approximately centered in pilot assembly. If not, loosen electrode locking nut, rotate assembly and tighten nut.
7. To check static pressure on pilot air, drill a #60 hole in the pilot air tube (red circle, Figure 16) and use a manometer for the reading. Pressure must be more than .35" w.c.

Figure 15 Pilot Spark Gap

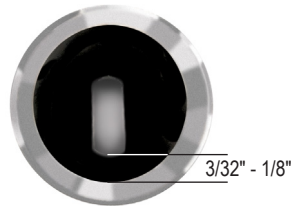

NOTICE The butterfly gas valve is factory set to a preliminary setting of 30 open for low fire, and 90 open for high fire. The pilot regulator is set for 3.0 inches w.c. Use manometer in the pilot test port (Figure 16) provided to confirm settings

Figure 16 Pilot Test Port

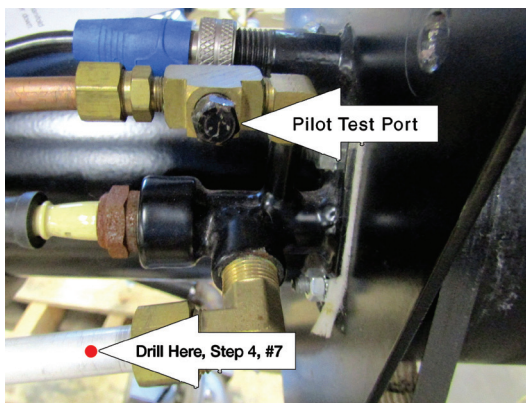

Step 5 (firing on gas) Set main gas pressure regulator

1. Leave the low-fire switch in low fire.
2. With the gas pilot operating correctly, and the UV sensor flame signal above minimum required, the primary control will cycle the burner to main gas.
3. Check the flame signal after the pilot has shut down to ensure the signal is still strong with main flame on.
4. Move the burner fuel selector switch to OFF. The burner will shut down.
5. Temporarily install two U-tube manometer connections to check gas pressures. Install connections at the inlet pressure tap of the main manual gas valve and at the downstream pressure tap of the manual gas valve next to the butterfly valve.
6. The gas pressure at the inlet to the gas train must never exceed 14 inches w.c., either when the burner is off or firing on gas.
7. Move the burner fuel selector switch to GAS. The burner should start.
8. With the burner firing in low fire, check the gas pressure at the downstream manual gas valve tapping. Adjust the main gas pressure regulator if necessary until the gas pressure reads 3.4 inches w.c. as a starting pressure.
9. Switch the low-fire switch to high fire. **CAUTION:** Be prepared to turn the burner off immediately if it begins to pulsate as it attempts to move to high fire.
10. If the flame pulsates, it is probably too rich. Switch the low-fire switch to low fire and reduce the gas pressure by adjusting the main gas pressure regulator. Then return to 9, above.
11. If the fire is too lean, it will appear small and can even blow out during the swing to high fire. If it blows out, shut off the burner immediately. Switch the low-fire switch to low fire and start the burner again. Adjust the main gas pressure regulator to increase the gas pressure. Return to 9, above.

WARNING With the burner running in high fire, inspect the red butterfly valve indicator. The indicator must be at 90, IF NOT, turn burner off. Loosen the 7/16" nuts holding the Tuthill joint to the butterfly valve arm. In small increments move joint closer to butterfly shaft if indicator arm is less than 90 and away from shaft if indicator is past 90.

12. With the burner running in high fire, adjust the main gas pressure regulator to match O₂ numbers set on oil. Measure the CO content. It should be no greater than 100 PPM.

NOTICE High CO readings may indicate the combustion is on the wrong side of the CO₂ curve. You will know this if a decrease in gas pressure causes an increase in CO₂.

13. The gas pressure may have to be set as low as about 2.0 inches w.c. to as high as about 4.0 inches w.c., depending on the firing rate of the burner.

8. Adjust the burner using test instruments (continued)

Step 6 (firing on gas)

Set butterfly gas valve linkage

1. Switch the low-fire hold switch to low fire.
2. Check CO₂ and CO. The CO₂ should be between 9.0% and 10.0% (natural gas) or between 10.0% and 11.2% (propane); with CO less than 100 PPM.
3. To adjust the low-fire air (change CO₂), move the burner fuel selector switch to OFF. Adjust the butterfly gas valve linkage as described in the following to change the low-fire gas flow to the burner head. Do not change the main gas pressure regulator setting.
4. **DO NOT ADJUST THE LOW-FIRE AIR DAMPER SETTING.** This must be left as set for oil firing.
5. See Figure 17 for location of linkage components.

Figure 17 Butterfly gas valve linkage

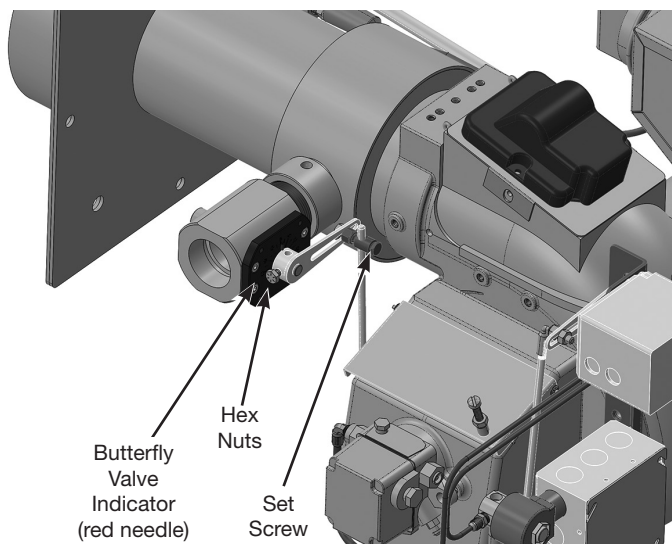

NOTICE To adjust the linkage, loosen set screw in the adjustable link in small increments. A 1/8-inch move can cause CO₂ to change as much as 1.5%.

- If more gas is needed (to increase CO₂), slide linkage UP.
 - If less gas is needed (to decrease CO₂), slide linkage DOWN.
6. Tighten the set screw in the adjustable link.
 7. **The butterfly valve indicator must be at 90°.** IF NOT, turn burner off. Loosen the 7/16" nuts holding the Tuthill joint to the butterfly valve arm. In small increments move joint closer to butterfly shaft if indicator arm is less than 90 and away from shaft if indicator is past 90.
 8. Restart and repeat as necessary until CO₂ and CO are acceptable.

**IF EQUIPPED WITH LOW-HIGH GAS PRESSURE SWITCH,
PROCEED TO STEP 6A.
OTHERWISE PROCEED TO STEP 7.**

**FOR MASS CODE, PROCEED TO STEP 6A,
OTHERWISE PROCEED TO STEP 7.**

Step 6a (firing on oil and on gas)

Verify operation

NOTICE Perform all of the checkout procedures given in Step 6 of the burner manual. In addition, verify operation of the gas pressure switches as described below.

Verify high gas pressure switch operation

- Cycle the burner off with the appliance controls and turn off power to the appliance/burner.
- Attach a manometer to the manifold-side manual gas valve test port.
- Turn on power and cycle the burner on with the appliance controls.
- Measure the manifold gas pressure with the manometer.
- Set the high gas pressure switch to a pressure less than actual manifold pressure. The high gas pressure switch should shut the burner down. Replace the switch if necessary.
- Turn off power to the appliance/burner; remove the manometer and replace the plug in the gas valve test port. Reset switch.

Verify low gas pressure switch operation

- Cycle the burner off with the appliance controls and turn off power to the appliance/burner.
- Close the main manual gas valve.
- Cycle the burner on.
- The low gas pressure switch should shut the burner down. Replace the switch if necessary.
- Turn off power to the appliance/burner.
- Open the main manual gas valve.
- Reset low gas pressure switch.

8. Adjust the burner using test instruments (continued)

Step 7 (firing on oil and on gas)

Verify operation

Burner/appliance/controls operation

- Test operating and limit controls on appliance as specified in appliance instructions.
- Check operation of the primary control by forcing lockout to occur. For primary controls that enter latch-up after multiple lockouts, force latch-up to occur as well. Reset primary control per control data sheet instructions after each test.
- Start and stop the burner several times, allowing the primary control to sequence through normal operation. Verify correct operation of burner and primary control throughout on both oil and gas.
- Confirm and/or adjust overfire combustion pressure for oil and gas operation. Refer to boiler/furnace manufacturer's recommendations.

Verify vent system operation

- Verify vent is operating correctly and flue products are properly exhausted from building. If the building contains any exhaust fans or conditions that could affect vent performance, check burner/appliance/vent operation with exhaust fans (or other conditions) operating.

Combustion/ventilation air

- Verify combustion/ventilation air openings are not, and will not be obstructed.
- Verify air opening louvers are fully open.
- If louvers are motor-operated, verify motor and end switch are interlocked with appliance/burner wiring to prevent operation of the burner if the air louvers are not fully opened.

Prepare burner for normal operation

- Cycle burner off with appliance controls.
- Turn off power to the appliance.
- Seal the appliance flue test opening.
- Verify all components and wires are in place and burner is ready for operation.
- Restore power to the appliance.

Train the user

- Train the user to operate the burner and appliance under normal conditions.
- Explain the procedure to shut down the burner/appliance when required.
- Review the back cover of this manual (and the appliance manual) with the user.
- Verify the user is aware of all procedures specified in the manuals.
- Verify that the user will not store or use combustible liquids or materials or contaminants in the vicinity of the burner/appliance.

9. Maintenance and service procedures

WARNING Turn off power to appliance when servicing burner. After servicing, always operate burner/appliance to verify all components are functioning correctly and that the burner is properly adjusted. Failure to comply could result in severe personal injury, death or substantial property damage.

General maintenance

Cleaning blower wheel

1. The blower wheel accumulates dust and debris from normal operation. You will need to clean the wheel blades periodically to prevent reduction in airflow. Inspect the blower wheel regularly by opening the housing cover.
2. To clean blades, when necessary, remove the bolts securing the motor to the blower housing.
 - a. Slide the motor out and rotate to remove and access blower wheel.
 - b. Use a brush and vacuum to clean each blade and the blower housing interior.
 - c. Install motor/wheel in blower housing and secure with the two bolts.
 - d. Push wire slack back into panel.

Replacing blower motor or wheel

1. If either the blower wheel or motor must be replaced, remove the bolts securing the motor to housing.
2. Disconnect the motor wires in the burner junction box (coming from the motor contactor).
3. Loosen the Allen screw securing the blower to the motor shaft and remove the wheel.
4. When assembling the replacement assembly, slide the wheel onto the motor shaft and use feeler gauges to set space between the blower wheel and the motor face. This space must be 3/64 inch.
5. Install the motor/wheel assembly in the housing, wire the motor leads and secure the motor with the two bolts.

Motor maintenance

- Refer to motor manufacturer's instructions for oiling the motor as needed.

Checking ignitor

WARNING Never test an ignitor by placing a screwdriver (or other metallic object) across the high voltage clips. This could cause ignitor damage or severe personal injury.

1. Checking 45000 ignitors only:
 - Disconnect electrical power to burner.
 - Open the burner access cover and remove ignitor wires from the electrodes. Lightly clamp each ignitor wire to the burner housing, with the wire ends pointed toward one another, spaced apart by a 3/8" to 1/2" gap.
 - Carefully energize ignitor and check for spark arcing at the high voltage terminals. If spark jumps the gap, ignitor is good.

Removing the combustion head assembly

1. To check the electrode settings or change the nozzle, you must remove the combustion head assembly from the air tube. Follow the steps below, and reverse the sequence to reassemble.
2. Shut off the burner.
3. Disconnect the 1/4" O.D. copper oil line.
4. Remove the two housing cover locking screws and swing the housing open.
5. Partially remove the combustion head assembly, and disconnect the two ignition cables from the electrodes and thermal fuse wire.
6. Remove the combustion head assembly from the tube.

Thermal fuse

1. When the burner is in a high-overfire draft condition, and not properly adjusted, it is possible that the flame could flash back inside the air tube. If this occurs, the thermal fuse will open in less than two seconds. The fuse must be replaced. (The burner is supplied with spare fuses.) The thermal fuse is wired in series with the air flow switch and will trigger an airflow switch lockout message if the fuse is blown.

Annual start-up and service

WARNING This burner must be started and serviced at least annually by a qualified service technician. Failure to properly maintain and service the burner could result in severe personal injury, death or substantial property damage.

- Discuss burner/appliance operation with user to determine any problems that may have occurred during the previous season and to verify user is aware of proper operation and care of the burner/appliance.
- Review proper operation of the appliance/burner unit with the user.
- Turn off power to appliance.
- Remove combustion head assembly to clean and adjust if necessary. (See above.)
- If the inside surface of the air tube and/or retention ring need to be cleaned, clean them with a vacuum cleaner with brush attachment while the combustion head assembly is out of the burner.
- Replace the oil nozzles with the correct sizes specified in this manual or the OEM guide.
- Inspect and adjust the ignition electrodes and insulators per instructions on page 10, Figure 3 of this manual. Replace if proper spacing cannot be achieved or if components are damaged.
- Close the housing cover plate and secure in place.
- Inspect the fuel line oil filter. Replace if necessary.
- Perform the complete checkout procedures of pages 20 to 26, including system inspection and checks.
- Inform the user of any problems found.

9. Maintenance and service procedures (continued)

| Installation/service certificate | | | | | |
|--|---|--|----------------------------|---|-------------------------|
| Installation data | | | | | |
| Burner model | Serial number | Measured gas firing rate, Btuh | Oil nozzle size & pattern: | Manifold gas pressure, IWC (High fire/Low fire) | Inlet gas pressure, IWC |
| CO2% Oil Low Fire: _____ Oil High Fire: _____ Gas Low Fire: _____ Gas High Fire: _____ | O2% Oil Low Fire: _____ Oil High Fire: _____ Gas Low Fire: _____ Gas High Fire: _____ | Nozzle pressure: • High fire: _____ PSIG • Low fire: _____ PSIG Fuel unit vacuum ("Hg) • High fire: _____ InHg • Low fire: _____ InHg | | Were controls tested? | |
| | | | | Adequate oil filtration installed? | |
| Comments about installation/start-up: | | | | | |
| | | | | | |
| Installer's name: | Company name: | | Company address: | | Phone: |
| | | | | | |
| Service history | | | | | |
| Date | Technician | Company/address | | Describe work performed | |
| | | | | | |
| | | | | | |
| | | | | | |
| | | | | | |

10. Dimensions

Figure 18 Dimensional data, straight gas train configuration

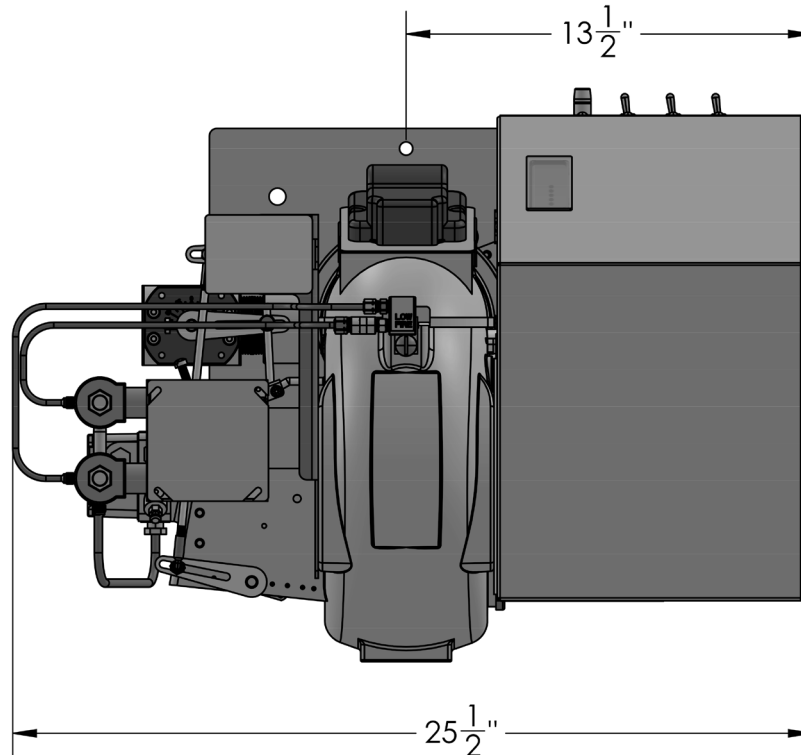
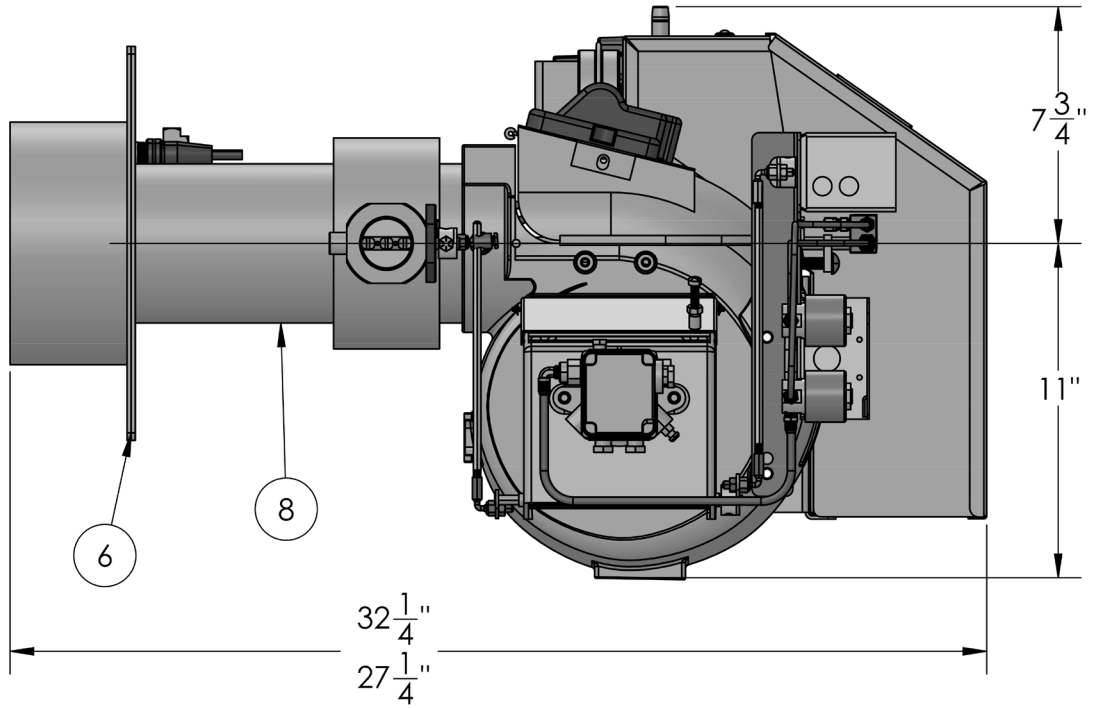

10. Dimensions (continued)

Figure 19 Dimensional data, angled gas train configuration

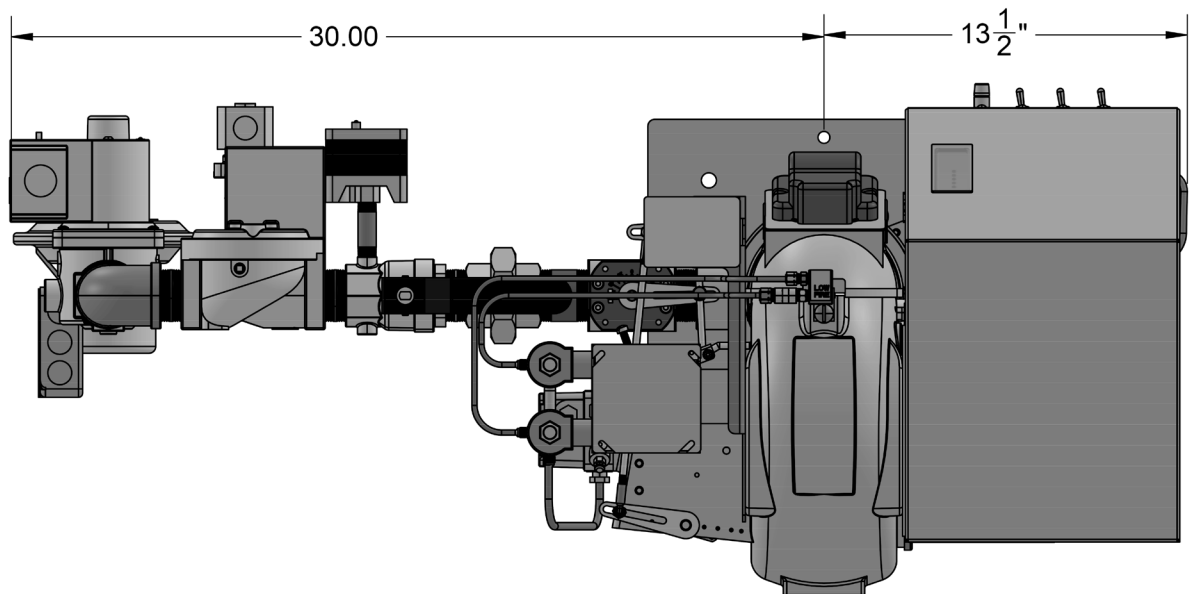
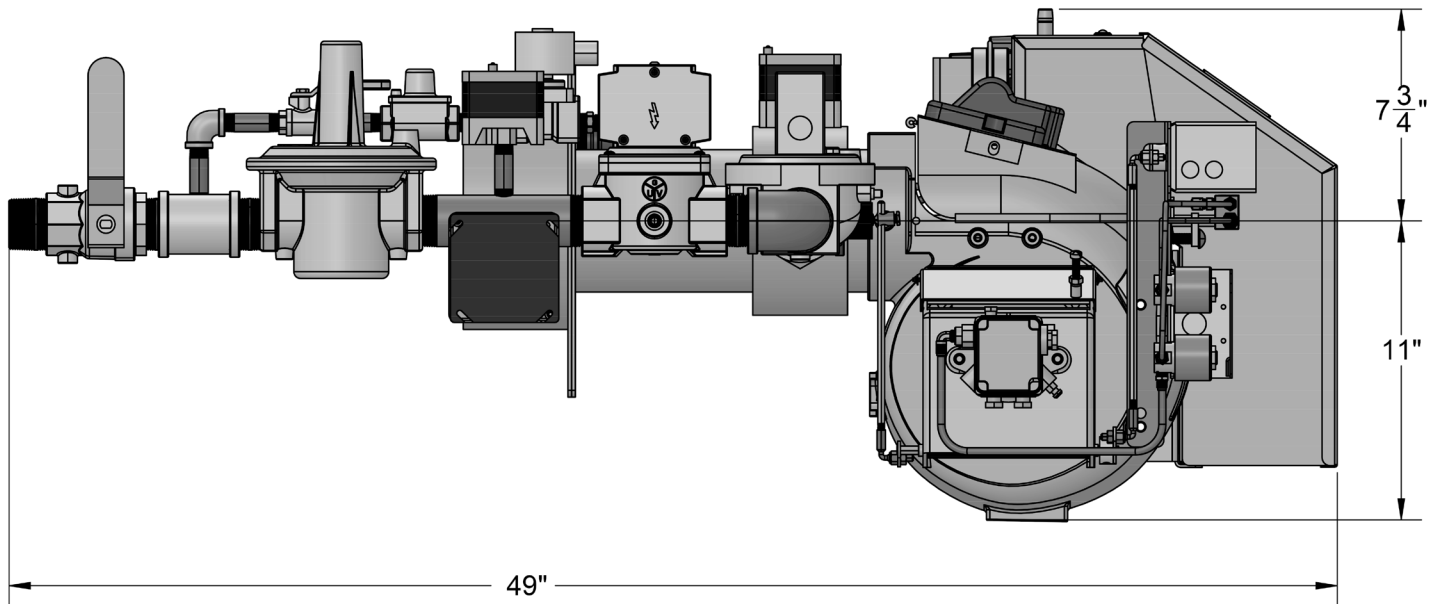

For parts not shown or listed, contact factory and/or check separate documentation supplied with appliance/burner unit.

11. Repair parts — Burner housing and components

| ITEM | PART NO. | DESCRIPTION | 801G/O |
|------|-----------|--|--------|
| 1 | 27730S | Motor: 3/4HP 115/208-230V 60HZ, 1 Phase, 3450 RPM | • |
| | 27557S | Motor: 1 1/2HP 115/208-230V 60HZ, 1 Phase, 3450 RPM | • |
| 2 | 98507S | Electorde Set of 2, Approx. 9 1/4" OAL | • |
| 3 | 56069S | Ignition Wire: 9 1/4" OAL for Nominal 10" AT (2 Req'd) | • |
| 4 | 51564S | 15" Tube with pressurized flange 1-1/2" main gas inlet; external pilot; 4" UTL | • |
| 5 | 98522S | Air Flow Switch 120 Volt | • |
| 6 | 51573S | Gasket | • |
| 7 | 51317S | Damper Motor - SQN71 | • |
| 8 | 41004S | Instant Oil Valve 32Z0078TSCV 3 Way | • |
| | 61150KITS | Oil Valve Kit (44560, 29678, 44461, 29728, 44545) | • |
| 9 | 98042S | Fuel Unit, 2 Stage, B2TA-8260 | • |
| | 98126S | Fuel Unit, 2 Stage, B2TA-8260, NYC | • |
| 10 | 51393CS | 15" Combustion Head Assembly (includes thermal fuse and electrode wire) | • |
| 11 | 4180002FS | Gas Ignitor | • |
| | 45000S | Oil Ignitor | • |
| | 45000S0LC | Ignitor on Baseplate | • |
| 12 | 28548S | Blower Wheel/Fan: 7" OD x 5 W, 5/8" Bore | • |
| | 28555S | Blower Wheel/Fan: 7 5/8" OD x 5" W, 5/8" Bore | • |

| ITEM | PART NO. | DESCRIPTION | 801G/O |
|------|-----------|--|--------|
| 13 | 98229S | Coupling: 1/2" ID x 5/16" ID x 6 1/2" L, B Pump | • |
| | 28779S | Coupling: 1/2" ID x 7/16" ID x 5 13/16" L, H or J Pump | • |
| 14 | 56812S | Retention Ring Assy 801CRD | • |
| 15 | 75461KITS | Oil Line Kit For 801G/O | • |
| 16 | 35824S | Motor Contactor 20 AMP R4242B1005 (Not Shown) | • |
| 17 | 51541S | Damper Motor Linkage Kit 12" | • |
| | 51542S | Shutter Drive Linkage Kit 11" | • |
| 18 | 34215S | Thermal fuse | • |
| 19 | 99716S | Toggle Switch (Not Shown) | • |
| 20 | 35311S | C7027A1023 UV Scanner | • |
| | 97656S | Q7800B1003 Sub Base | • |
| | 99766S | RM7897C1000 Programming Control | • |
| | 97662S | R7849A1023 Amplifier | • |
| | 97716S | ST7800A1054 Timing Card | • |
| | EMX51UVS | EMX51UV KIT includes all of the above | • |
| 21 | 23382S | Pedestal (Not Shown) | • |
| 22 | 51202S | Pilot assembly with ignitor and gasket | • |
| 22a | 513765 | Pilot ignitor | • |
| 23 | 46771S | Motor Mounting Ring | • |
| 24 | 48504S | Air Shutter Assembly (Not Shown) | • |

For parts not shown or listed, contact factory and/or check separate documentation supplied with appliance/burner unit.

11. Repair parts (continued)

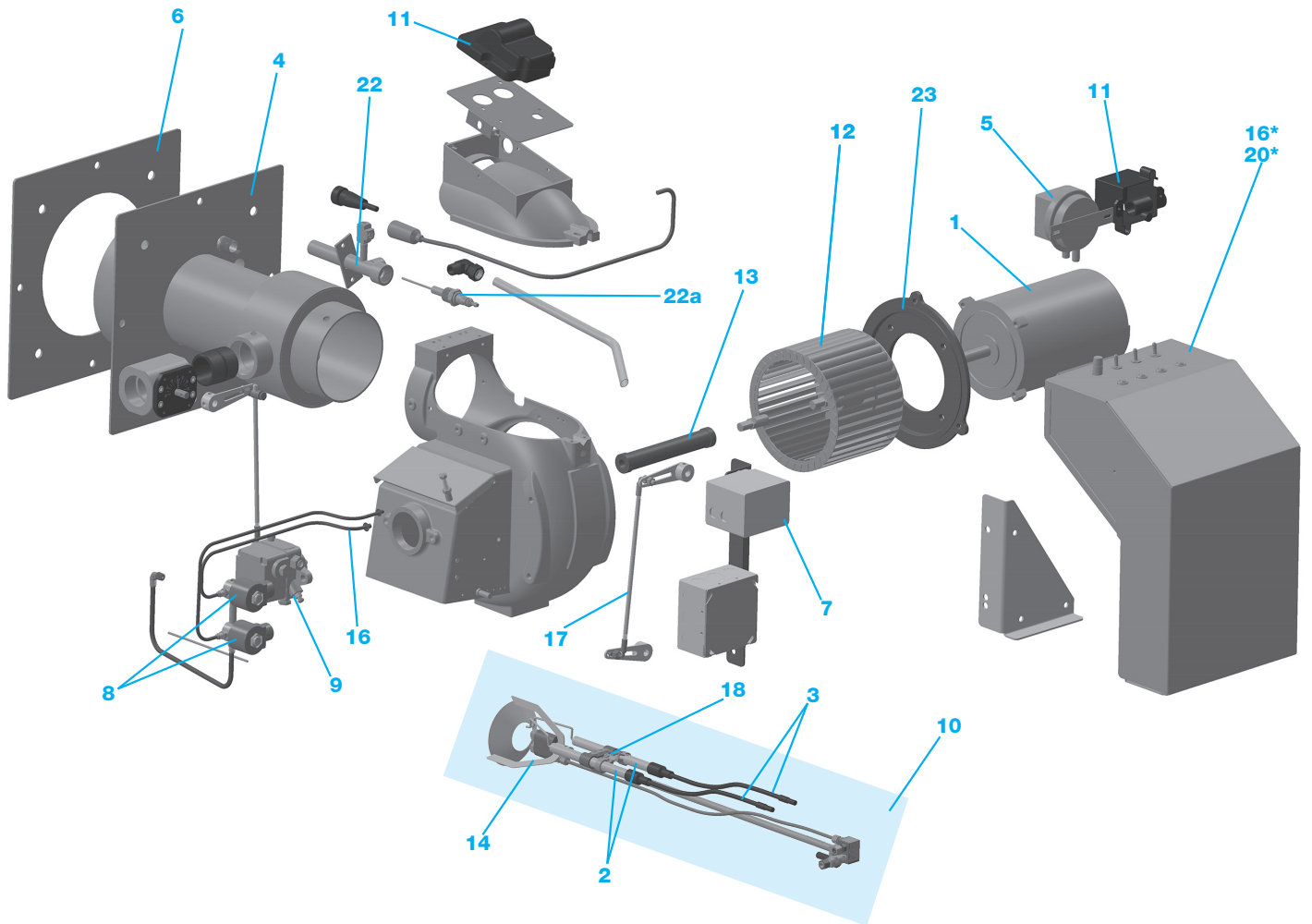

*Inside control panel

MODEL **SQL71**
**Damper
Actuator
Supplement**

Quick Reference Guide

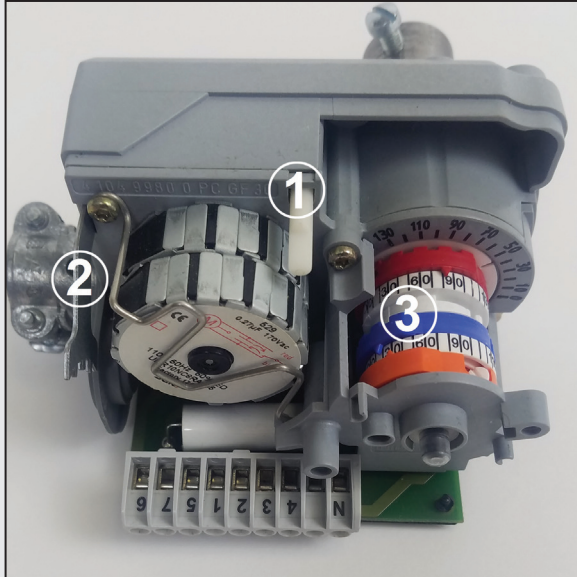

WARNING A control with a minimum 10-Second Post-Purge **MUST** be used with this Damper Motor to ensure the High-Fire Damper is closed at the end of the call for heat/at the start of your next call for heat.

WARNING Installer/servicer – Except where specifically stated otherwise, this Supplement must be used only by a **qualified service technician**. Follow all guidelines in the Burner Manual and Boiler Manual. Failure to comply with this or other requirements in this manual could result in severe personal injury, death or substantial property damage.

| Reference Number | Description |
|------------------|--|
| 1 | Disengaging Pin (In the engaged position)* |
| 2 | Adjustment Wrench |
| 3 | Cam Stack |
| 4 | Damper Position Scale (Damper position indicated by slit in the white ring) |
| 5 | Red Cam (High-Fire) |
| 6 | Blue Cam (Low-Fire) |
| 7 | Transition Cam (Shares adjustment scale with Blue Cam)** |

*To rotate damper and cam stack by hand, disengaging pin must be pushed in. The pin must be out when the burner is operating

**Transition cam sets the transition point between Low Fire and High Fire

NOTE: Before setting your cams, make sure the disengaging pin is pushed in.

All Carlin burners with the SQN71 damper motor should be set at the recommend settings shown in the table at the right.

| CAM INDICATION | | | | | |
|----------------|--------|------------|----------------|--------------------------|--------------------------------|
| Cam # | Color | Position | Settings | | |
| | | | 701CRD, 702CRD | 801CRD, 1050FFD, 1150FFD | 702G/O, 702GAS, 801G/O, 801GAS |
| I | Red | High-Fire | 90 | 90 | 60-70 |
| II | Blue | Low-Fire | 10 | 0 | 0 |
| III | Orange | Transition | 50 | 45 | 30-40 |

Please reference above chart for exact settings.

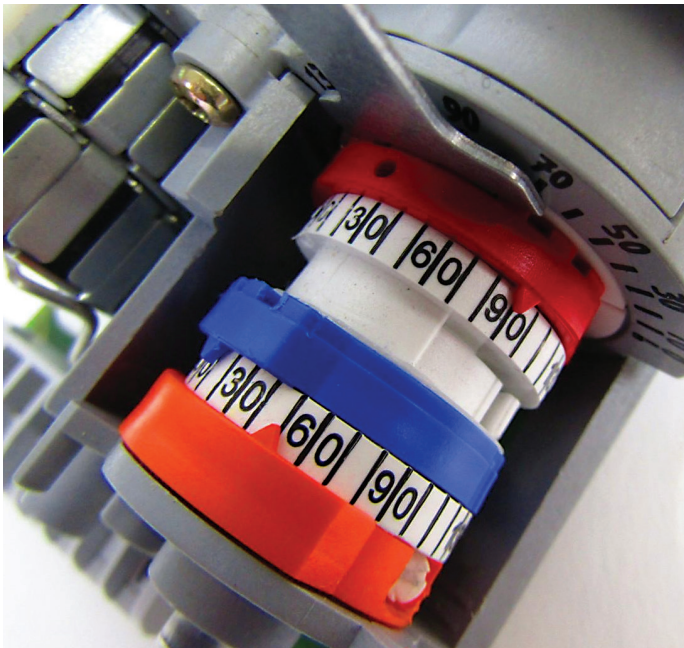

Setting High Fire (Red Cam)

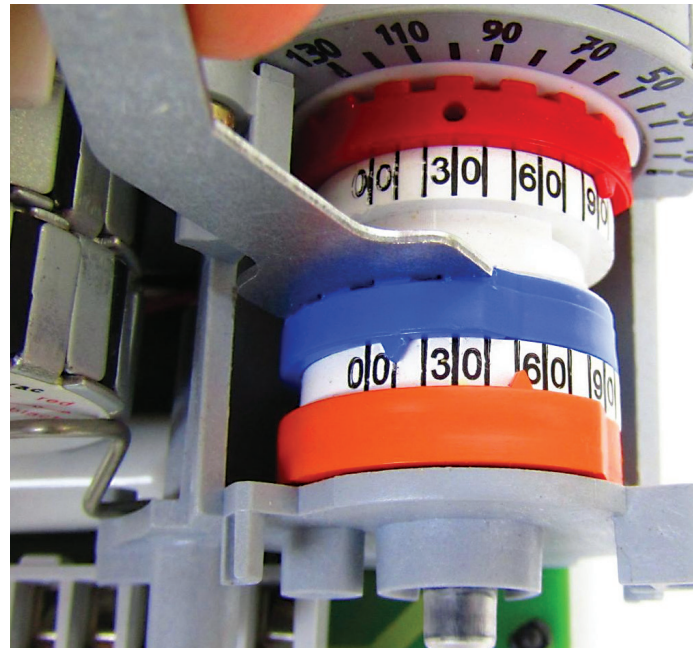

Setting Low Fire (Blue Cam)



Setting Transition (Orange Cam)
Transition cam is set with a screwdriver. Transition should be set half way between High Fire and Low Fire to start. Adjust if necessary.

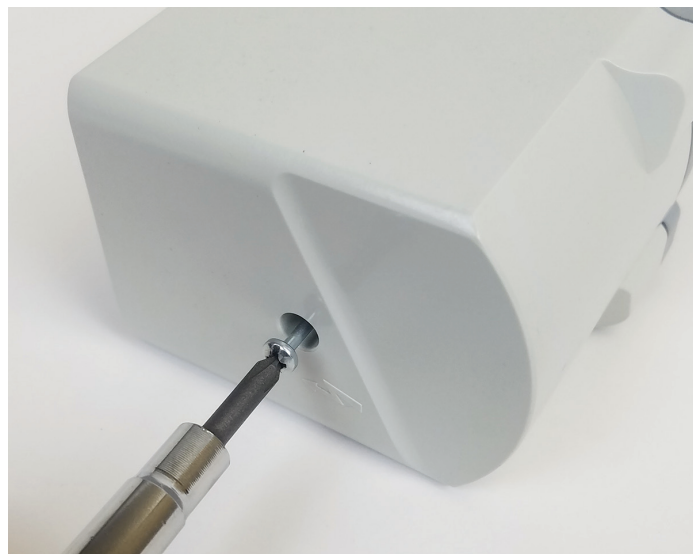

Replacing Cover
Before putting on the actuator cover, be sure the disengaging pin has been engaged.

Carlin[®]
Combustion Technology

Tech Hotline: 800-989-2275
 Phone 203-680-9401 Fax 203-680-9403
 126 Bailey Road, North Haven, CT 06473
www.carlincombustion.com

801G/O burner

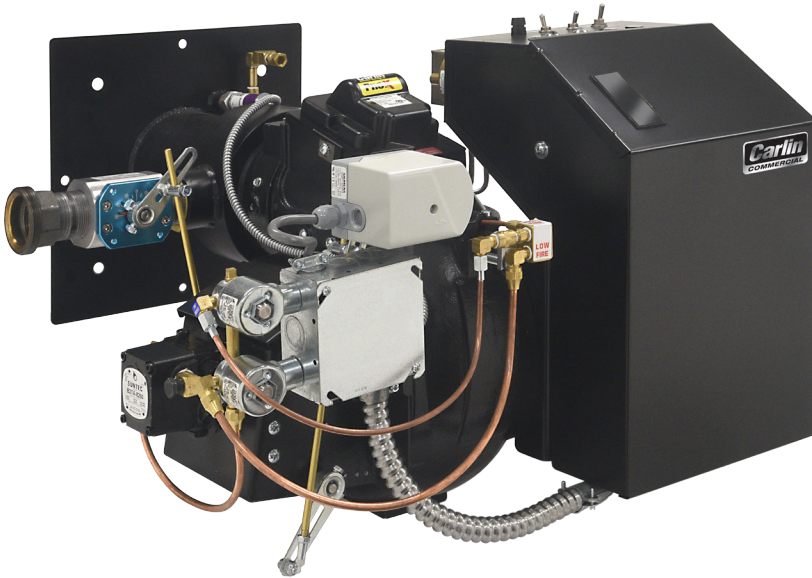

WARNING The burner must be cleaned, tested and adjusted annually by a qualified burner service technician.

WARNING Should overheating occur:

- (1) Shut off both fuel supplies to the burner.
- (2) DO NOT shut off the control switch to the circulator or blower.
- (3) Contact your oil dealer or service technician and the fire department (if needed).

User care and maintenance

WARNING Refer only to the information on this page, intended for your use. The remainder of this manual is intended only for your service technician. Failure to comply could result in severe personal injury, death or substantial property damage.

For other than routine maintenance, contact a qualified service company. Perform the following as needed.

- Keep the area around the burner clear and free from combustible vapors and liquids.
- Do not obstruct the flow of combustion and ventilating air.
- Most motors currently used on commercial type burners use permanently-lubricated bearings, and do not require field lubrication. Read the label on the motor to determine oiling needs, if any. Do not over-lubricate. This can cause as much trouble as not lubricating at all.

WARNING Never attempt to use gasoline as a fuel for this burner, as it is more combustible and could result in a serious explosion. Never attempt to burn refuse or use any fuel other than # 1 or # 2 heating oil including bio blends not exceeding B20 (U.S ONLY) (ASTM D396).